

Motion control

Lexium integrated drives

Catalogue

September **2011**



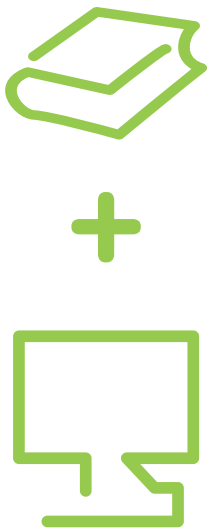

All technical information about products listed in this catalogue are now available on:
www.schneider-electric.com

Browse the “product data sheet” to check out :

- characteristics,
- dimensions,
- curves, ...
- and also the links to the user guides and the CAD files.

1 From the home page, type the model number* into the “Search” box.



* type the model number without any blank, replace “.” by “*”

2 Under “All” tab, click the model number that interests you.

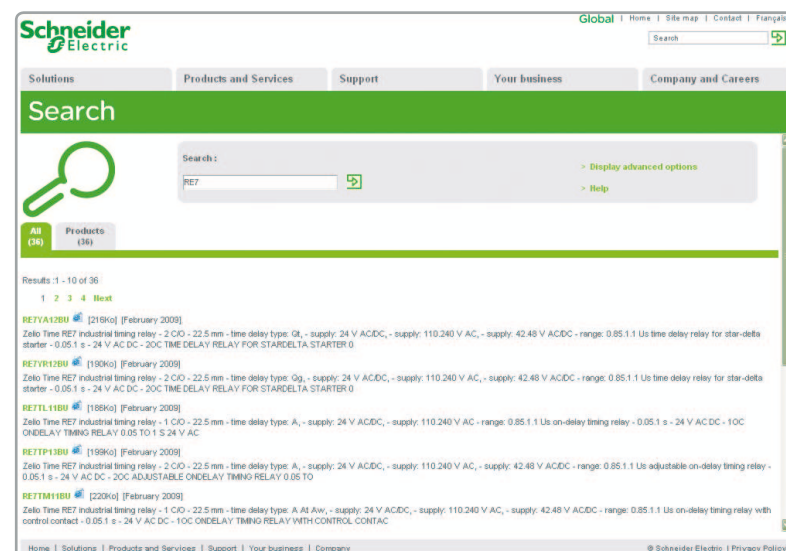

3 The product data sheet displays.

Example : Zelio Time data sheet

Zelio Time-RE 7 / RE 8 / RE 9
Timer relays that are simply ingenious

RE7YA12BU
Zelio Time RE7 industrial timing relay - 2 C/O - 22.5 mm - time delay type: Ot - supply: 110...240 V AC, - supply: 42...48 V AC/DC - range: 0.85...1.1 Us

range of product	Zelio Time
product or component type	industrial timing relay
discrete output type	relay
width pitch dimension	22.5 mm
contacts type and composition	2 C/O
component name	RE7
contacts material	90/10 silver nickel contacts
time delay type	Ot
time delay range	0.05 ... 300 h
[UR] rated supply voltage	24 V AC/DC 50/60 Hz
	110...240 V AC 50/60 Hz
	42...48 V AC/DC 50/60 Hz
product weight	0.15 kg
voltage range	0.85...1.1 Us
lightening torque	0.6...1.1 N m
CAD overall width	22.5 mm
CAD overall height	78 mm
CAD overall depth	80 mm

Discover this product

- Characteristics
- Functions
- Connection
- Dimensions
- Download & Documents

Other products

- Help me to choose
- Accessories**
- Plug
- Sockets

Example : Zelio Time data sheet

Zelio Time-RE 7 / RE 8 / RE 9
Timer relays that are simply ingenious

RE7YA12BU
Zelio Time RE7 industrial timing relay - 2 C/O - 22.5 mm - time delay type: Ot - supply: 110...240 V AC, - supply: 42...48 V AC/DC - range: 0.85...1.1 Us

Example : Zelio Time data sheet

Zelio Time-RE 7 / RE 8 / RE 9
Timer relays that are simply ingenious

RE7YA12BU
Zelio Time RE7 industrial timing relay - 2 C/O - 22.5 mm - time delay type: Ot - supply: 110...240 V AC, - supply: 42...48 V AC/DC - range: 0.85...1.1 Us

☑ You can get this information in one single pdf file.

Motion control

Lexium integrated drives

- **Presentation of the offer** page 4
- **IL●1 integrated drives for CANopen, PROFIBUS DP and RS 485 serial link**
 - Presentation page 6
 - ILA1 integrated drives with AC synchronous servo motor page 10
 - ILE1 integrated drives with DC brushless motor page 12
 - ILS1 integrated drives with 3-phase stepper motor page 14
- **IL●2 integrated drives for DeviceNet, EtherCAT, EtherNet/IP, Modbus TCP and Ethernet POWERLINK**
 - Presentation page 16
 - ILA2 integrated drives with AC synchronous servo motor page 20
 - ILE2 integrated drives with DC brushless motor page 22
 - ILS2 integrated drives with 3-phase stepper motor page 24
- **ILS1 integrated drives with I/O interface for motion sequence**
 - Presentation page 26
 - References page 30
- **ILS1 integrated drives with pulse/direction (P/D) interface**
 - Presentation page 32
 - References page 34
- **Accessories for ILA, ILE and ILS integrated drives** page 36
- **Option: GB● planetary gearboxes** page 40
- **ILP●R integrated drives for RS 485 serial link**
 - Presentation page 44
 - References page 48
- **ILT●A integrated drives for CANopen machine bus**
 - Presentation page 50
 - References page 54
- **ILT●V integrated drives with pulse/direction (P/D) interface**
 - Presentation page 56
 - References page 58
- **Accessories for ILP and ILT integrated drives** page 60

Motion control Lexium integrated drives

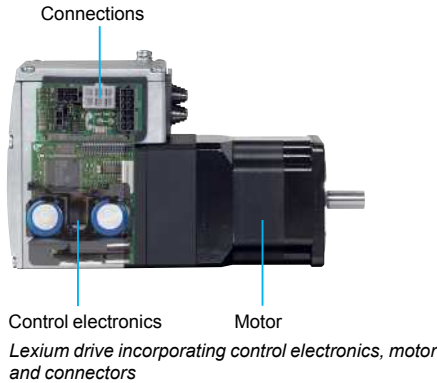

Presentation

Lexium integrated drives are used to create decentralized motion control solutions in very compact units.

They consist of a motor and control electronics. They are controlled via a communication bus, a pulse/direction (P/D) interface or an I/O interface (for the "Motion sequence" operating mode).

Lexium integrated drives are used as decentralized drives in machine building. When combined with a Schneider Electric Lexium Controller or a PLC, they can be used to create complex control system architectures simply and at minimum cost. Ready-to-use function blocks are available for programming movements with Schneider Electric or third-party motion controllers.

Maximum compactness

The motor and control electronics form a compact unit. This decentralized unit does not require any space in the enclosure for the control electronics, thus reducing the size of the machine.

Simple to install and commission

Integration of the motor and the control electronics reduces the installation costs and simplifies incorporation of electromagnetic compatibility. In addition, Lexium CT PC software provides rapid commissioning.

Optimum flexibility to adapt to your application

The integrated drives can be equipped with an AC synchronous servo motor, a DC brushless motor or a stepper motor, thus providing numerous possibilities for use in a wide variety of applications.

Depending on the technology used, they can thus meet requirements for dynamic performance, flexibility or precision in motion control applications.

Open communication with control system architectures

Depending on the model, Lexium integrated drives incorporate as standard the main communication protocols used in industry for increased performance of your applications:

- CANopen, PROFIBUS DP, DeviceNet, EtherCAT, EtherNet/IP, Ethernet POWERLINK and Modbus TCP communication buses and networks
- RS 485 serial link

Integrated drives with stepper motor are also available with a pulse/direction (P/D) interface or an I/O interface for the motion sequence.

This open communication concept enables integration in numerous control system architectures.

Integrated safety

The integrated Safe Torque Off (Power Removal) safety function enables a category 0 or 1 stop to be performed in accordance with standard IEC/EN 60204-1 without external power protection devices.

The integrated drive does not have to be switched off, which reduces the system costs and the restart times. The drive complies with the requirements of the following standards: IEC/EN 61508 SIL2, ISO 13849-1 performance level "d" (PL d) and IEC/EN 61800-5-2 (STO).

Applications

Lexium integrated drives are suitable for the most common applications, including:

- Packaging
- Material handling, labelling
- Textiles
- Printing
- Electronic components
- Medical technology

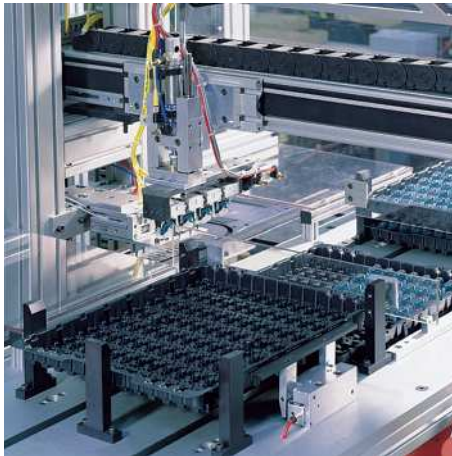

Material handling application



Labelling application

Motion control

Lexium integrated drives

Lexium CT commissioning software

Presentation (continued)

The commissioning time for Lexium integrated drives is considerably reduced using the Lexium CT (Lexium Commissioning Tool) PC software.

It is used for commissioning, parameter setting, simulation and diagnostics.

Functions

Lexium CT PC software includes the following functions:

- Entry and display of parameters
- Archiving and duplication of parameters
- Display of status information
- Positioning of the motor via the PC
- Initiation of homing movements
- Access to all documented parameters
- Fault diagnostics
- Controller optimization (for ILA integrated drive)

Required configuration

Lexium CT software runs on a PC with the Microsoft Windows® 2000/XP/Vista operating systems. The integrated drive is commissioned via the communication interface.

Download

Lexium CT software can be downloaded from our website:
www.schneider-electric.com.

Motion control

Lexium integrated drives

IL●1 for CANopen, PROFIBUS DP, RS 485



ILA1 with AC synchronous servo motor



ILE1 with brushless servo motor



ILS1 with stepper motor

Presentation

Lexium IL●1 integrated drives comprise a motor, control electronics and a communication interface for:

- CANopen DS301 machine bus (IL●1F)
- PROFIBUS DP V0 fieldbus (IL●1B)
- RS 485 serial link (IL●1R)

The communication bus interface is used for setting parameters and controlling the integrated drives, as well as for commissioning using Lexium CT software.

Lexium IL●1 integrated drives also have an RS 485 serial link interface and an interface for four 24 V signals, which can be configured as either inputs or outputs to suit application requirements.

They also include the Safe Torque Off (Power Removal) safety function as standard, which prevents unintended motor operation.

The control section comprises control electronics and a power stage which share a common power supply.

Lexium IL●1 integrated drives can operate on a 24 V to 36 V $\overline{\text{---}}$ supply.

Three motor technologies are offered to cover a wide range of applications.

Adaptability assured by three motor technologies

The Lexium IL●1 integrated drive range offers three motor technologies to meet the requirements for dynamic performance, flexibility or precision in a wide variety of applications:

ILA1: the integrated drive for dynamic processes

The ILA1 integrated drive is equipped with an AC synchronous servo motor. This motor features high dynamic performance, as it can be temporarily boosted when accelerating.

Application example: bottling

Bottles are transported on a conveyor up to the filling point, where their presence is detected by a sensor.

The Lexium ILA1 drive activates a pump to start filling the bottle then ensures accurate filling and instant stop to avoid overflowing by means of its closed loop function.

ILE1: the integrated drive for automatic format adjustment

The ILE1 integrated drive is equipped with a DC brushless motor.

This motor has a high automatic holding torque, which makes the use of a holding brake unnecessary in the majority of applications.

The control electronics incorporated in the ILE1 drive provide absolute encoder functionality.

Application example: ground-mounted solar power plants

The latest solar power plants are equipped with biaxial tracking systems (azimuth/zenith).

Each axis is controlled by two Lexium ILE1 integrated drives.

The Lexium ILE1 drive was chosen for its high holding torque and because it totally eliminates the need for electrical cabinets.

ILS1: the integrated drive for short range positioning

With its 3-phase stepper motor, the ILS1 integrated drive offers high torque values at low rotation speeds.

In rotation speed mode, it has excellent stability characteristics and also enables high resolution positioning tasks.

Commissioning an ILS1 integrated drive with stepper motor is simple as it does not require any configuration of the control loop.

Application example: labelling machine

The Lexium ILS integrated drive's high torque is used to control the unrolling speed of the label roll.

Motion control

Lexium integrated drives

IL●1 for CANopen, PROFIBUS DP, RS 485

Interfaces

Communication bus interface

Depending on the model, the following communication buses can be connected:

- CANopen machine bus (protocol DS301)
- PROFIBUS DP V0 fieldbus (data format according to Profidrive V2.0 PPO type 2)
- RS 485 serial link

The communication bus interface is used for setting parameters and controlling the integrated drive.

It is also used as an option for connecting the terminal when commissioning the integrated drive using Lexium CT PC software (see page 5). A suitable communication bus converter is then required, for example CAN/USB, PROFIBUS DP/USB or RS 485/USB.

RS 485 serial link interface

The Lexium IL●1 integrated drive is commissioned by default via the RS 485 serial link interface.

This interface also accesses the drive's integrated control/monitoring function. This function can also be accessed via the Lexium CT PC software.

The communication bus and RS 485 serial link can be connected simultaneously.

Interface for 24 V signals

Four 24 V signals are available, configurable as inputs or outputs. They can also be used for predefined functions such as limit switches or reference sensors. They can be used by the master controller.

The 24 V power for the outputs is provided internally via the integrated drive's power supply.

Interface for integrated Safe Torque Off function

The Safe Torque Off (Power Removal) safety function enables a category 0 or 1 stop to be performed in accordance with IEC/EN 60204-1 and/or prevents unintended motor operation in accordance with IEC/EN 61508 level SIL2, ISO 13849-1 performance level "d" (PL d) and IEC/EN 61800-5-2 (STO). No additional power protection is necessary.

The Lexium IL●1 integrated drive can remain powered up, which reduces system costs and the restart time.

The Safe Torque Off function is activated via two redundant 24 V input signals (active in OFF state).

Special technical features

ILA1 with AC synchronous servo motor

- High dynamic performance and high peak torque
- Choice of:
 - single turn high resolution encoder, 16,384 points/turn (0.02°)
 - multiturn high resolution encoder, 16,384 points/turn (0.02°) for 4096 turns
- Integrated holding brake available as an option
- Planetary gearbox available as an option

ILE1 with DC brushless motor

- High automatic holding torque
- Absolute encoder: no homing required after switching off/on
- Can be equipped with integral straight-tooth gearbox or tapered worm gearbox
- Planetary gearbox available as an option

ILS1 with 3-phase stepper motor

- High continuous stall torque
- Good speed stability characteristics
- High encoder accuracy (0.018°)
- Holding brake available as an option for ILS1●85 integrated drive
- Planetary gearbox available as an option

Motion control

Lexium integrated drives

IL●1 for CANopen, PROFIBUS DP, RS 485



Integrated drive with printed circuit board connectors

Connection

Two types of connector are available depending on the types of machine to be equipped.

They are used to connect the communication buses, the RS 485 serial link, the interfaces for 24 V signals and the Safe Torque Off function, as well as the power supply.

Printed circuit board connectors

Printed circuit board connectors are preferably used for wiring standard machines with cable harnesses.

The Lexium IL●1 integrated drive is connected by means of two cable entry plates, to be ordered separately (see accessories page 36).

Industrial connectors

Integrated drives with industrial connectors are preferably used for special machines and small series production machines.

The communication buses and the power supply are connected by means of the industrial connectors located on the top of the drive.

The RS 485 serial link, the 24 V signals and the Safe Torque Off function are connected via two plates fitted with industrial connectors, to be ordered separately (see accessories pages 36 and 38).



Integrated drive with industrial connectors

Compliance with international standards and certifications

The Lexium integrated drives offer has been developed in accordance with strict international standards and recommendations for variable speed electrical power drive products, in particular IEC/EN 61800-3 (immunity to disturbance related to high frequency signals connected by cables and transmitted) and IEC/EN 50178 (vibration resistance).

Compliance with electromagnetic compatibility requirements has been incorporated in the design of the Lexium integrated drive range. The entire range conforms to international standard IEC/EN 61800-3:2001, environment 2.

Lexium integrated drives carry the CE marking in accordance with the European machinery directive (98/37/EEC) and the European EMC directive (2004/108/EEC).

The entire range is cULus certified (United States and Canada).

It is also TÜV certified in accordance with safety standards for medical devices and equipment. This certification covers:

- Functional safety of electrical/electronic/programmable electronic safety-related systems (IEC 61508: 2000; SIL 2)
- Safety of machinery – functional safety of safety-related electrical, electronic and programmable electronic control systems (IEC 62061: 2005; SILcl2)
- Safety of machinery – safety-related parts of electronic control systems – part 1: General principles for design (ISO 13849-1: 2006; PL d (category 3))

Motion control

Lexium integrated drives

IL●1 for CANopen, PROFIBUS DP, RS 485

Main functions

Lexium IL●1 integrated drives include the main functions required for motion control, in particular:

Configuration by means of parameter switches

The following settings can be performed using the parameter switches in the integrated drive:

- CANopen DS301 and RS 485 serial link:
 - setting of the communication bus address
 - setting of the transmission rate
 - end of line termination activation
 - setting of the pulse/direction (P/D) signals or encoder (A/B) signals to “electronic gearbox” mode for integrated drive ILA1●57 equipped with a single turn encoder
- PROFIBUS DP V0:
 - setting of the fieldbus address
 - end of line termination activation

Operating modes

The following operating modes can be set via the communication bus:

- electronic gearbox (for drive ILA1●57 with single turn encoder)
- speed profile
- manual (JOG)
- point-to-point
- homing

Other operating modes can be activated via the communication bus or with Lexium CT PC software:

- activation of the motor brake
- reversal of direction of rotation of the motor
- setting of the motion profile via the profile generator
- setting of the motor phase current
- triggering of the Quick Stop function
- fast position capture via an input signal
- configuration of I/O signals
- scaling of drive internal units to user units
- control/monitoring functions

Note: For details of available functions, please visit our website www.schneider-electric.com.

Motion control Lexium integrated drives

IL●1 for CANopen, PROFIBUS DP, RS 485
ILA1 with AC synchronous servo motor

Description

ILA1 integrated drives consist of control electronics with an interface for CANopen DS301, PROFIBUS DP or RS 485 communication bus and an AC synchronous servo motor.

They can be equipped with a single turn or multiturn encoder as required.

For ILA1 integrated drives equipped with a single turn encoder, an integrated holding brake is also available as an option.

Two types of connection are possible:

- Printed circuit board connectors
- Industrial connectors

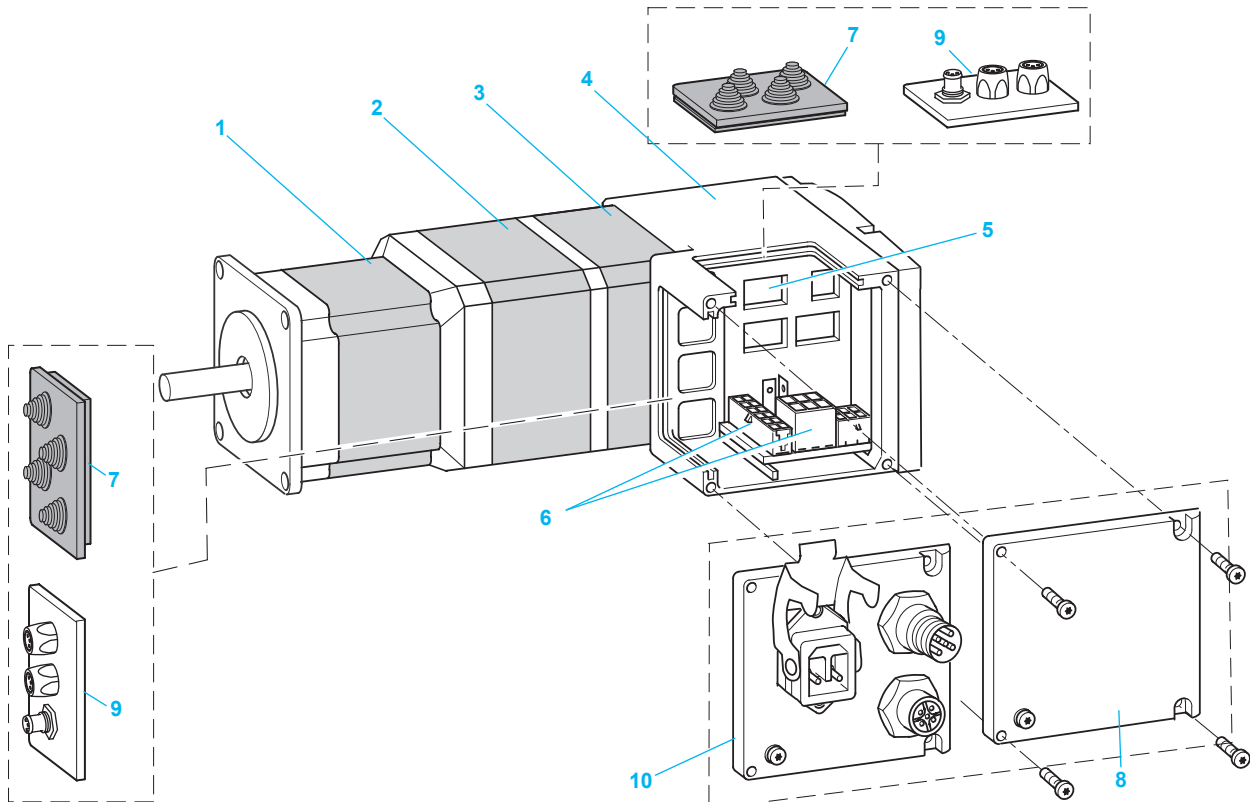

- 1 AC synchronous servo motor
- 2 Integrated holding brake (optional)
- 3 Single turn or multiturn encoder
- 4 Electronic unit
- 5 Parameter switch
- 6 Connection terminals

For drive with printed circuit board connector:

7 Cable entry plate (see accessories page 36)

8 Cover

For drive with industrial connector:

9 Plate for connecting I/O and the Safe Torque Off function (see accessories page 38)

10 Cover for connecting the 24/36 V $\bar{---}$ power supply and the communication bus (see accessories page 38)

Note: I/O connection plate equipped with industrial connectors for RS 485 serial link, CANopen machine bus and PROFIBUS DP communication bus: 2 round connectors (1 round connector for each signal, IN and OUT).

Motion control

Lexium integrated drives

IL●1 for CANopen, PROFIBUS DP, RS 485
ILA1 with AC synchronous servo motor



ILA1 integrated drive with AC synchronous servo motor

References													
Example:	I	L	A	1	B	5	7	1	P	B	1	A	0
Motor type A = AC synchronous servo motor	I	L	A	1	B	5	7	1	P	B	1	A	0
Supply voltage 1 = 24...36 V	I	L	A	1	B	5	7	1	P	B	1	A	0
Communication interface B = PROFIBUS DP F = CANopen DS301 R = RS 485	I	L	A	1	B	5	7	1	P	B	1	A	0
Flange size 57 = 57 mm	I	L	A	1	B	5	7	1	P	B	1	A	0
Drive type (1) 1 = ILA1●571 2 = ILA1●572	I	L	A	1	B	5	7	1	P	B	1	A	0
Winding type (1) P = medium rotation speed T = high rotation speed	I	L	A	1	B	5	7	1	P	B	1	A	0
Connection B = printed circuit board connector C = industrial connector	I	L	A	1	B	5	7	1	P	B	1	A	0
Encoder type 1 = single turn encoder (16,384 points/turn) 2 = multiturn encoder (16,384 points/turn x 4096 turns) (2)	I	L	A	1	B	5	7	1	P	B	1	A	0
Holding brake A = without holding brake F = with holding brake (2)	I	L	A	1	B	5	7	1	P	B	1	A	0
Gearbox 0 = without gearbox	I	L	A	1	B	5	7	1	P	B	1	A	0

(1) See the main characteristics and dimensions according to the type of drive in the table below:

Drive		ILA1●571				ILA1●572				
Winding type		T		P		T		P		
Nominal supply voltage	V ~	24	36	24	36	24	36	24	36	
Nominal speed of rotation	rpm	5100	7500	3200	5500	3100	5000	2600	4300	
Peak stall torque	Nm	0.43		0.6		0.61		0.72		
Continuous stall torque	Nm	0.26				0.41		0.45		
Dimensions (overall in mm)	With single turn encoder	W x H x D	57.2 x 92.2 x 145.3				57.2 x 92.2 x 163.8			
	With multiturn encoder	W x H x D	57.2 x 92.2 x 189.3				57.2 x 92.2 x 207.8			
	With holding brake	W x H x D	57.2 x 92.2 x 190.8				57.2 x 92.2 x 209.3			

(2) The holding brake and the multiturn encoder cannot be used together.

Note: See all the data (characteristics, dimensions) on our website www.schneider-electric.com.

Motion control Lexium integrated drives

IL●1 for CANopen, PROFIBUS DP, RS 485
ILE1 with DC brushless motor

Description

ILE1 integrated drives consist of control electronics with an interface for CANopen DS301, PROFIBUS DP or RS 485 communication bus and a DC brushless motor.

They are available with straight-tooth gearbox or tapered worm gearbox and printed circuit board connectors or industrial connectors.

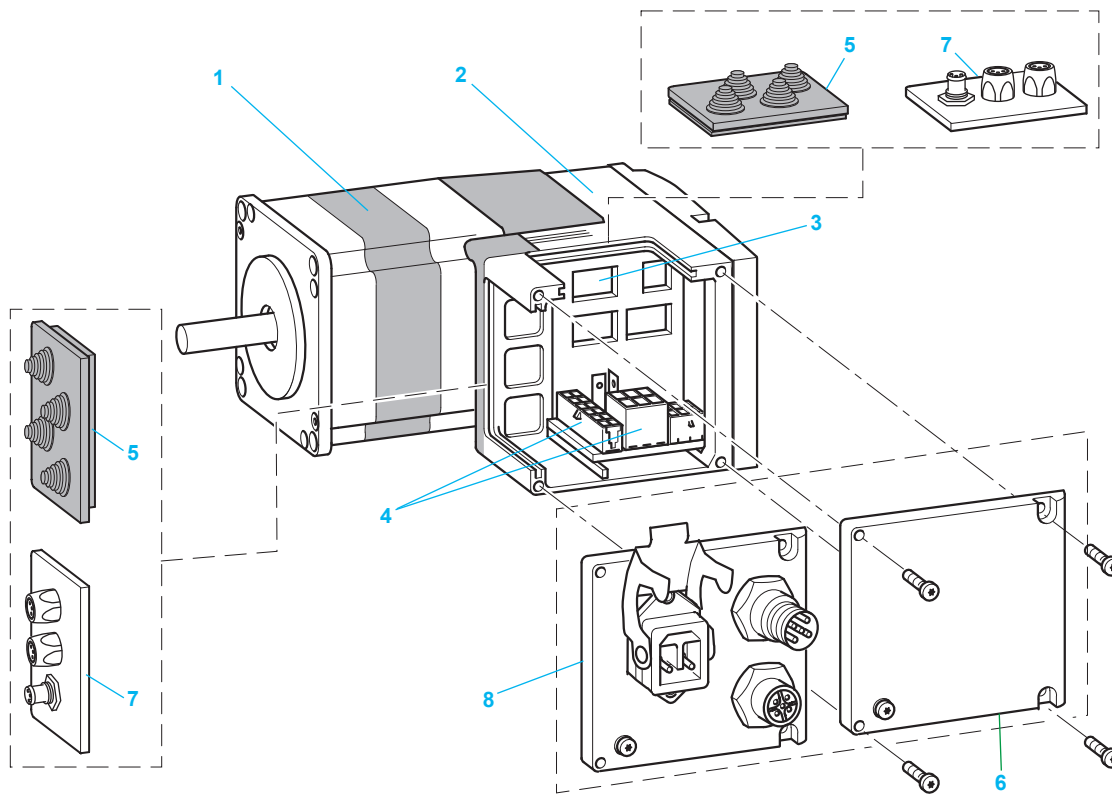

- 1 DC brushless motor
- 2 Electronic unit
- 3 Parameter switch
- 4 Connection terminals

For integrated drive with printed circuit board connector:

- 5 Cable entry plate (see accessories page 36)

- 6 Cover

For integrated drive with industrial connector:

- 7 Plate for connecting I/O and the Safe Torque Off function (see accessories page 38)

- 8 Cover for connecting the 24/36 V $\overline{\text{V}}$ power supply and the communication bus (see accessories page 38)

Note: I/O connection plate equipped with industrial connectors for RS 485 serial link, CANopen machine bus and PROFIBUS DP communication bus: 2 round connectors (1 round connector for each signal, IN and OUT).

Motion control

Lexium integrated drives

IL●1 for CANopen, PROFIBUS DP, RS 485
ILE1 with DC brushless motor



ILE1 integrated drive with brushless servo motor



ILE1 integrated drive with brushless servo motor and straight-tooth gearbox

References	
Example:	I L E 1 B 6 6 1 P B 1 A 1
Motor type E = DC brushless motor	I L E 1 B 6 6 1 P B 1 A 1
Supply voltage 1 = 24...36 V	I L E 1 B 6 6 1 P B 1 A 1
Communication interface B = PROFIBUS DP F = CANopen DS301 R = RS 485	I L E 1 B 6 6 1 P B 1 A 1
Flange size 66 = 66 mm	I L E 1 B 6 6 1 P B 1 A 1
Drive type (1) 1 = ILE1●661	I L E 1 B 6 6 1 P B 1 A 1
Winding type (1) P = medium rotation speed	I L E 1 B 6 6 1 P B 1 A 1
Connection B = printed circuit board connector C = industrial connector	I L E 1 B 6 6 1 P B 1 A 1
Encoder type 1 = encoder for DC brushless motor (12 points/turn)	I L E 1 B 6 6 1 P B 1 A 1
Holding brake A = without holding brake	I L E 1 B 6 6 1 P B 1 A 1
Gearbox 0 = without gearbox	I L E 1 B 6 6 1 P B 1 A 1
Straight-tooth gearbox	
1 = reduction ratio 18:1 (160:9)	
2 = reduction ratio 38:1 (75:2)	
3 = reduction ratio 54:1 (490:9)	
4 = reduction ratio 115:1 (3675:32)	
Tapered worm gearbox	
5 = reduction ratio 24:1 (525:22)	
6 = reduction ratio 54:1 (1715:32)	
7 = reduction ratio 92:1 (735:5)	
8 = reduction ratio 115:1 (3675:32)	

(1) See the main characteristics and dimensions according to the type of drive in the table below:

Drive		ILE1●661	
Nominal supply voltage	V $\overline{\text{---}}$	24	36
Nominal current	A	4.7	5.1
Nominal speed of rotation	rpm	4000	4800
Nominal torque	Nm	0.175	0.24
Maximum torque	Nm	0.26	0.36
Detent torque (at zero current)	Nm	0.1	0.06
Dimensions (overall in mm)	Without gearbox	W x H x D	66 x 104 x 122
	With straight-tooth gearbox	W x H x D	66 x 104 x 174
	With worm gearbox	W x H x D	66 x 104 x 229

Note: See all the data (characteristics, dimensions) on our website www.schneider-electric.com.

Motion control Lexium integrated drives

IL●1 for CANopen, PROFIBUS DP, RS 485
ILS1 with 3-phase stepper motor

Description

ILS1 integrated drives consist of control electronics with an interface for CANopen DS301, PROFIBUS DP or RS 485 communication bus and a 3-phase stepper motor.

For ILS1●85 integrated drives, an integrated holding brake is also available as an option.

Two types of connection are possible:

- Printed circuit board connectors
- Industrial connectors

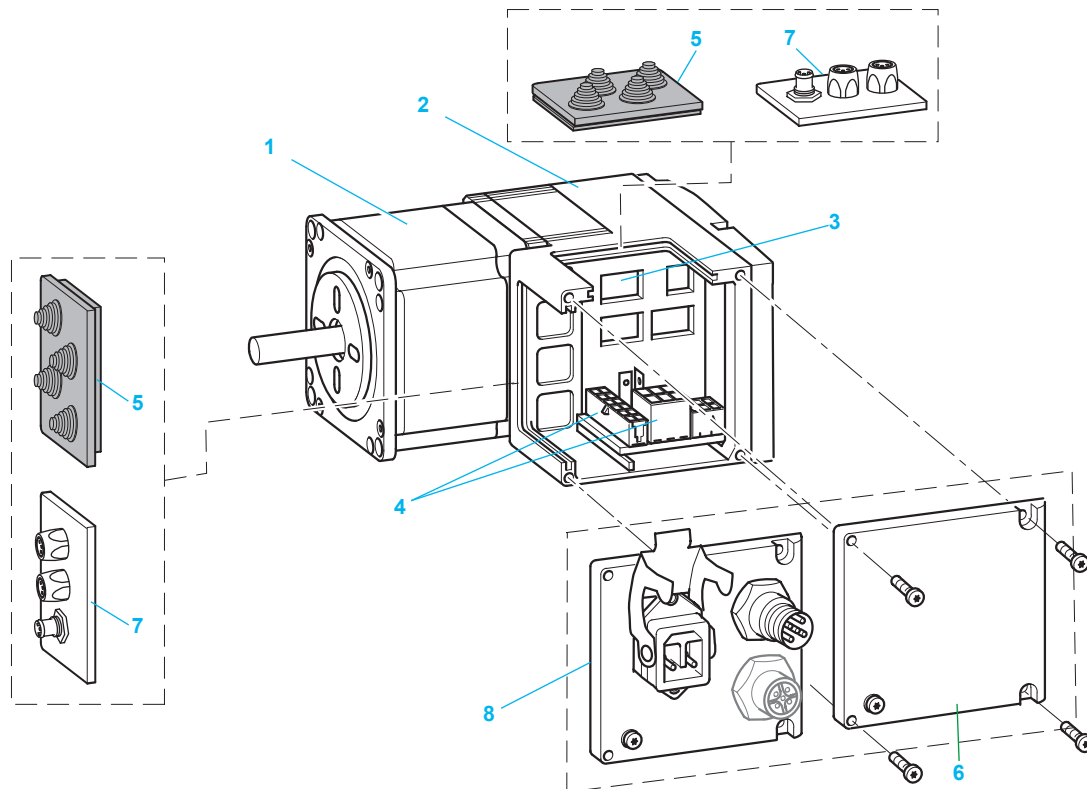

1 3-phase stepper motor

2 Electronic unit

3 Parameter switch

4 Connection terminals

For drive with printed circuit board connector:

5 Cable entry plate (see accessories page 36)

6 Cover

For drive with connector for industrial circuit:

7 Plate for connecting I/O and the Safe Torque Off function (see accessories page 38)

8 Cover for connecting the 24/36 V $\overline{\text{V}}$ power supply and the communication bus (see accessories page 38)

Note: I/O connection plate equipped with industrial connectors for RS485 serial link, CANopen machine bus and PROFIBUS DP communication bus: 2 round connectors (1 round connector for each signal, IN and OUT).

Motion control

Lexium integrated drives

IL●1 for CANopen, PROFIBUS DP, RS 485
 ILS1 with 3-phase stepper motor



ILS1 integrated drive with stepper motor

References													
Example:	I	L	S	1	B	5	7	1	P	B	1	A	0
Motor type S = 3-phase stepper motor	I	L	S	1	B	5	7	1	P	B	1	A	0
Supply voltage 1 = 24...36 V	I	L	S	1	B	5	7	1	P	B	1	A	0
Communication interface B = PROFIBUS DP F = CANopen DS301 R = RS 485	I	L	S	1	B	5	7	1	P	B	1	A	0
Flange size 57 = 57 mm 85 = 85 mm	I	L	S	1	B	5	7	1	P	B	1	A	0
Drive type (1) 1 = ILS1●●●1 2 = ILS1●●●2 3 = ILS1●●●3	I	L	S	1	B	5	7	1	P	B	1	A	0
Winding type (1) P = medium rotation speed T = high rotation speed (2)	I	L	S	1	B	5	7	1	P	B	1	A	0
Connection B = printed circuit board connector C = industrial connector	I	L	S	1	B	5	7	1	P	B	1	A	0
Sensor type 1 = reference pulse sensor (Zero marker)	I	L	S	1	B	5	7	1	P	B	1	A	0
Holding brake A = without holding brake F = with holding brake (3)	I	L	S	1	B	5	7	1	P	B	1	A	0
Gearbox 0 = without gearbox	I	L	S	1	B	5	7	1	P	B	1	A	0

(1) See the main characteristics and dimensions according to the type of drive in the table below:

Drive		ILS1●571	ILS1●572	ILS1●573	
Winding type		P	P	P	
Nominal speed of rotation	rpm	1000	600	450	
Maximum torque	Nm	0.45	0.9	1.5	
Holding torque	Nm	0.51	1.02	1.7	
Dimensions (overall in mm)	W x H x D	57.2 x 92.2 x 101.9	57.2 x 92.2 x 115.9	57.2 x 92.2 x 138.9	
Drive		ILS1●851	ILS1●852	ILS1●853	
Winding type		P	P	P	T
Nominal speed of rotation	rpm	450	200	120	300
Maximum torque	Nm	2	4	6	4.5
Holding torque	Nm	2	4	6	4.5
Dimensions (overall in mm)	Without holding brake	W x H x D	85 x 119.6 x 140.6	85 x 119.6 x 170.6	85 x 119.6 x 200.6
	With holding brake	W x H x D	85 x 119.6 x 187.3	85 x 119.6 x 217.3	85 x 119.6 x 247.3

(2) Twinding only available for integrated drive with 85 mm flange (ILS1●853).

(3) Holding brake only available for integrated drive with 85 mm flange (ILS1●85).

Note: See all the data (characteristics, dimensions) on our website www.schneider-electric.com.

Motion control

Lexium integrated drives

IL●2 for DeviceNet, EtherCAT, EtherNet/IP, Modbus TCP, Ethernet POWERLINK



ILA2 with AC synchronous servo motor



ILE2 with brushless servo motor



ILS2 with stepper motor

Presentation

Lexium IL●2 integrated drives comprise a motor, control electronics and a communication interface for:

- DeviceNet (IL●2D)
- EtherCAT (IL●2E)
- EtherNet/IP (IL●2K)
- Modbus TCP (IL●2T)
- Ethernet POWERLINK (IL●2P)

The communication bus interface is used for setting parameters and controlling the integrated drives, as well as for commissioning using Lexium CT software.

Lexium IL●2 integrated drives also have an RS 485 serial link interface and an interface for four 24 V signals, which can be configured as either inputs or outputs to suit application requirements.

They also include the Safe Torque Off (Power Removal) safety function as standard, which prevents unintended motor operation.

The control section comprises control electronics and a power stage which share a common power supply.

Lexium IL●2 integrated drives can operate on a 24 V to 48 V $\overline{\text{---}}$ supply.

Three motor technologies are offered to cover a wide range of applications.

Adaptability assured by three motor technologies

The Lexium IL●2 integrated drive range offers three motor technologies to meet requirements for dynamic performance, flexibility or precision in a wide variety of applications:

ILA2: the integrated drive for dynamic processes

The ILA2 integrated drive is equipped with an AC synchronous servo motor. This motor features high dynamic performance, as it can be temporarily boosted when accelerating.

Application example: manufacture of CDs/DVDs
From the pressing of the CD or DVD right through to the end of its manufacture, the process is totally automated using Lexium ILA2 integrated drives, which increase productivity and reduce the production area by approximately 10%.

ILE2: the integrated drive for automatic format adjustment

The ILE2 integrated drive is equipped with a DC brushless motor. This motor has a high automatic holding torque. This makes the use of a holding brake unnecessary in the majority of applications. The control electronics incorporated in the ILE2 drive provide absolute encoder functionality.

Application example: manufacture of solar cells
Electrical circuits are printed using a silkscreen process. Lexium ILE2 integrated drives are used for conveying. Dynamic performance is significantly improved and the wiring time is reduced. Other integrated drives, such as Lexium ILS2, are also used for precise positioning, or Lexium ILA2 for the printing process.

ILS2: the integrated drive for short range positioning

With its 3-phase stepper motor, the ILS2 integrated drive offers high torque values at low rotation speeds. It is mainly used in rotation speed mode with excellent stability characteristics and also for high resolution positioning. The commissioning of ILS2 drives with stepper motor is simple as it does not require any configuration of the control loop.

Application example: wood processing
In applications using multi-blade circular saws, the planks are measured using lasers. They are positioned using linear axes equipped with a Lexium ILS2 integrated drive. Because of the harsh environmental conditions, the control cabinets are located some distance from the machinery. This concept of decentralization considerably reduces the wiring.

Motion control

Lexium integrated drives

IL●2 for DeviceNet, EtherCAT, EtherNet/IP,
Modbus TCP, Ethernet POWERLINK

Interfaces

Communication bus interface

Depending on the model, the following communication buses can be connected:

- DeviceNet
- EtherCAT (according to IEEE 802.3)
- EtherNet/IP (according to IEEE 802.3)
- Modbus TCP (according to IEEE 802.3)
- Ethernet POWERLINK (according to IEEE 802.3)

The communication bus interface is used for setting parameters and controlling the integrated drive.

It is also used as an option for connecting the terminal when commissioning the integrated drive using Lexium CT PC software (see page 5).

Connection to the DeviceNet fieldbus, available depending on the model, provides access to the ADR (Auto Device Replacement) function. If maintenance is required, this function enables drives to be replaced without having to redefine the parameters.

The communication bus and RS 485 serial link can be connected simultaneously.

RS 485 serial link interface

The Lexium IL●2 integrated drive is commissioned by default via the RS 485 serial link interface.

This interface also accesses the control/monitoring function included in the drive. This function can also be accessed via the Lexium CT PC software.

The communication bus and RS 485 serial link can be connected simultaneously.

Interface for 24 V signals

Four 24 V signals are available, configurable as inputs or outputs.

They can also be used to set the parameters of predefined functions such as limit switch detection.

They can be used by the master controller.

The 24 V power for the outputs is provided internally via the integrated drive's power supply.

Interface for integrated Safe Torque Off function

The Safe Torque Off (Power Removal) safety function enables a category 0 or 1 stop to be performed in accordance with standard IEC/EN 60204-1 and/or prevents unintended motor operation in accordance with standard IEC/EN 61508 level SIL2, ISO 13849-1 performance level "d" (PL d) and IEC/EN 61800-5-2 (STO).

No additional power protection option is necessary. The Lexium IL●1 integrated drive can remain powered up, which reduces system costs and the restart time.

The Safe Torque Off function is activated via two redundant 24 V input signals (active in OFF state).

Motion control

Lexium integrated drives

IL●2 for DeviceNet, EtherCAT, EtherNet/IP, Modbus TCP, Ethernet POWERLINK



Integrated drive with printed circuit board connectors

Special technical features

ILA2 with AC synchronous servo motor

- High dynamic performance and high peak torque
- Choice of:
 - Single turn high resolution encoder, 16,384 points/turn (0.02°)
 - Multiturn high resolution encoder, 16,384 points/turn (0.02°) for 4096 turns
- Integrated holding brake available as an option
- Planetary gearbox available as an option

ILE2 with DC brushless motor

- High automatic holding torque
- Absolute encoder: no homing required after switching off/on
- Can be equipped with integral straight-tooth gearbox or tapered worm gearbox
- Planetary gearbox available as an option

ILS2 with 3-phase stepper motor

- High continuous stall torque
- Good speed stability characteristics
- High encoder accuracy (0.018°)
- Holding brake available as an option for ILS2●85 integrated drive
- Planetary gearbox available as an option

Connection

Two types of connector are available depending on the types of machine to be equipped. They are used to connect the communication buses, the RS 485 serial link, the interfaces for 24 V signals and the Safe Torque Off function, as well as the power supply.

Printed circuit board connectors

Printed circuit board connectors are preferably used for wiring standard machines with cable harnesses.

The integrated drive is connected via two cable entry plates, to be ordered separately (see accessories page 36).

Industrial connectors

Integrated drives with industrial connectors are preferably used for special machines and small series production machines.

The communication buses and power supply are connected by means of the industrial connectors located on the top of the drive.

The RS 485 serial link, the 24 V signals and the Safe Torque Off function are connected via two plates fitted with industrial connectors, to be ordered separately (see accessories pages 36 and 38).



Integrated drive with industrial connectors

Motion control

Lexium integrated drives

IL●2 for DeviceNet, EtherCAT, EtherNet/IP,
Modbus TCP, Ethernet POWERLINK

Compliance with international standards and certifications

The Lexium integrated drive range has been developed in accordance with strict international standards and with the recommendations for variable speed electrical power drive products, in particular IEC/EN 61800-3 (immunity to disturbance related to high frequency signals connected by cables and transmitted) and IEC/EN 50178 (vibration resistance).

Compliance with electromagnetic compatibility requirements has been incorporated in the integrated drive range. The entire range conforms to international standard IEC/EN 61800-3:2001, environment 2.

Lexium integrated drives carry the CE marking in accordance with the European machinery directive (98/37/EEC) and the European EMC directive (2004/108/EEC).

The entire range is cULus certified (United States and Canada). It is also TÜV certified in accordance with the safety standards for medical devices and equipment. This certification covers:

- Functional safety of electrical/electronic/programmable electronic safety-related systems (IEC 61508: 2000; SIL 2)
- Safety of machinery – functional safety of safety-related electrical, electronic and programmable electronic control systems (IEC 62061: 2005; SILcl2)
- Safety of machinery – safety-related parts of electronic control systems – part 1: General principles for design (ISO 13849-1: 2006; PL d (category 3))

Main functions

Lexium IL●2 integrated drives include the main functions required for motion control, in particular:

Configuration by parameter switch

Depending on the communication bus, the following settings can be performed using the parameter switches in the integrated drive:

- DeviceNet:
setting of the communication bus address
- EtherCAT, EtherNet/IP, Modbus TCP and Ethernet POWERLINK:
setting of the IP address

Operating modes

The following operating modes can be set via the communication bus:

- Electronic gearbox (for ILA2 integrated drive with single turn encoder)
- Speed profile
- Manual (JOG)
- Point-to-point
- Homing

Other operating modes can be activated via the communication bus or the Lexium CT PC software:

- Activation of the motor brake
- Reversal of the direction of rotation of the motor
- Setting of the motion profile via the profile generator
- Setting of the motor phase current
- Triggering of the Quick Stop function
- Fast position capture via an input signal
- Configuration of I/O signals
- Scaling of units within the drive to user units
- Control/monitoring functions

Note: For details of available functions, please visit our website www.schneider-electric.com.

Motion control

Lexium integrated drives

IL2 for DeviceNet, EtherCAT, EtherNet/IP, Modbus TCP, Ethernet POWERLINK
 ILA2 with AC synchronous servo motor

Description

ILA2 integrated drives consist of control electronics with an interface for DeviceNet, EtherCAT, EtherNet/IP, Modbus TCP or Ethernet POWERLINK communication bus and an AC synchronous servo motor.

They can be equipped with a single turn or multiturn encoder as required.

For ILA2 integrated drives equipped with a single turn encoder, an integrated holding brake is also available as an option.

Two types of connection are possible:

- Printed circuit board connectors
- Industrial connectors

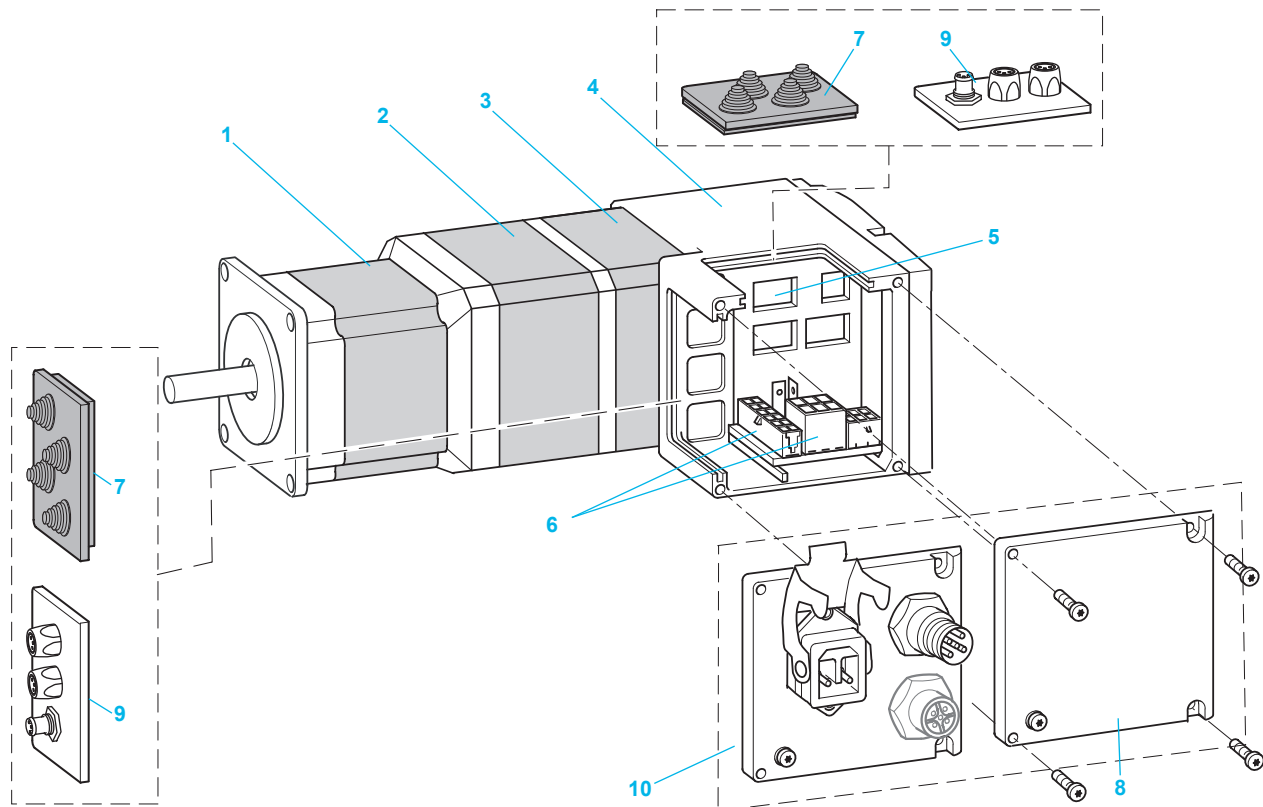

- 1 AC synchronous servo motor
- 2 Integrated holding brake (option)
- 3 Single turn or multiturn encoder
- 4 Electronic unit
- 5 Parameter switch
- 6 Connection units

For drive with printed circuit board connector:

7 Cable entry plate (see accessories page 36)

8 Cover

For drive with industrial connector:

9 Plate for connecting I/O and the Safe Torque Off function (see accessories page 38)

10 Cover for connecting the 24/48 V power supply and the communication bus (see accessories page 38)

Note: I/O connection plate equipped with industrial connectors for:

- DeviceNet and Modbus TCP communication bus: 1 round connector for IN and OUT signals
- EtherCAT, EtherNet/IP and Ethernet POWERLINK communication bus: 2 round connectors (1 round connector for each signal, IN and OUT).

Motion control

Lexium integrated drives

IL●2 for DeviceNet, EtherCAT, EtherNet/IP, Modbus TCP, Ethernet POWERLINK
ILA2 with AC synchronous servo motor



ILA2 integrated drive with AC synchronous servo motor

References													
Example:	I	L	A	2	D	5	7	1	P	B	1	A	0
Motor type A = AC synchronous servo motor	I	L	A	2	D	5	7	1	P	B	1	A	0
Supply voltage 2 = 24... 48 V	I	L	A	2	D	5	7	1	P	B	1	A	0
Communication interface D = DeviceNet E = EtherCAT K = EtherNet/IP P = Ethernet POWERLINK T = Modbus TCP	I	L	A	2	D	5	7	1	P	B	1	A	0
Flange size 57 = 57 mm	I	L	A	2	D	5	7	1	P	B	1	A	0
Drive type (1) 1 = ILA2●571 2 = ILA2●572	I	L	A	2	D	5	7	1	P	B	1	A	0
Winding type (1) P = medium rotation speed T = high rotation speed	I	L	A	2	D	5	7	1	P	B	1	A	0
Connection B = printed circuit board connector C = industrial connector	I	L	A	2	D	5	7	1	P	B	1	A	0
Encoder type 1 = single turn encoder (16,384 points/turn) 2 = multiturn encoder (2) (16,384 points/turn x 4096 turns)	I	L	A	2	D	5	7	1	P	B	1	A	0
Holding brake A = without holding brake F = with holding brake (2)	I	L	A	2	D	5	7	1	P	B	1	A	0
Without gearbox 0 = without gearbox	I	L	A	2	D	5	7	1	P	B	1	A	0

(1) See the main characteristics and dimensions according to the type of drive in the table below:

Drive		ILA2●571				ILA2●572				
Winding type		T		P		T		P		
Nominal supply voltage	V $\ddot{~}$	24	48	24	48	24	48	24	48	
Nominal speed of rotation	rpm	5000	7000	3200	5100	3000	5100	1600	3400	
Peak stall torque	Nm	0.45		0.62		0.85		1.62		
Continuous stall torque	Nm	0.31		0.44		0.57		0.78		
Dimensions (overall in mm)	With single turn encoder	W x H x D	57.2 x 92.2 x 145.3				57.2 x 92.2 x 163.8			
	With multiturn encoder	W x H x D	57.2 x 92.2 x 189.3				57.2 x 92.2 x 207.8			
	With holding brake	W x H x D	57.2 x 92.2 x 190.8				57.2 x 92.2 x 209.3			

(2) The holding brake and the multiturn encoder cannot be used together.

Note: See all the data (characteristics, dimensions) on our website www.schneider-electric.com.

Motion control Lexium integrated drives

IL●2 for DeviceNet, EtherCAT, EtherNet/IP,
Modbus TCP, Ethernet POWERLINK
ILE2 with DC brushless motor

Description

ILE2 integrated drives consist of control electronics with an interface for DeviceNet, EtherCAT, EtherNet/IP, Modbus TCP or Ethernet POWERLINK communication bus and a DC brushless motor.

They are available with straight-tooth gearbox or tapered worm gearbox and printed circuit board connectors or industrial connectors.

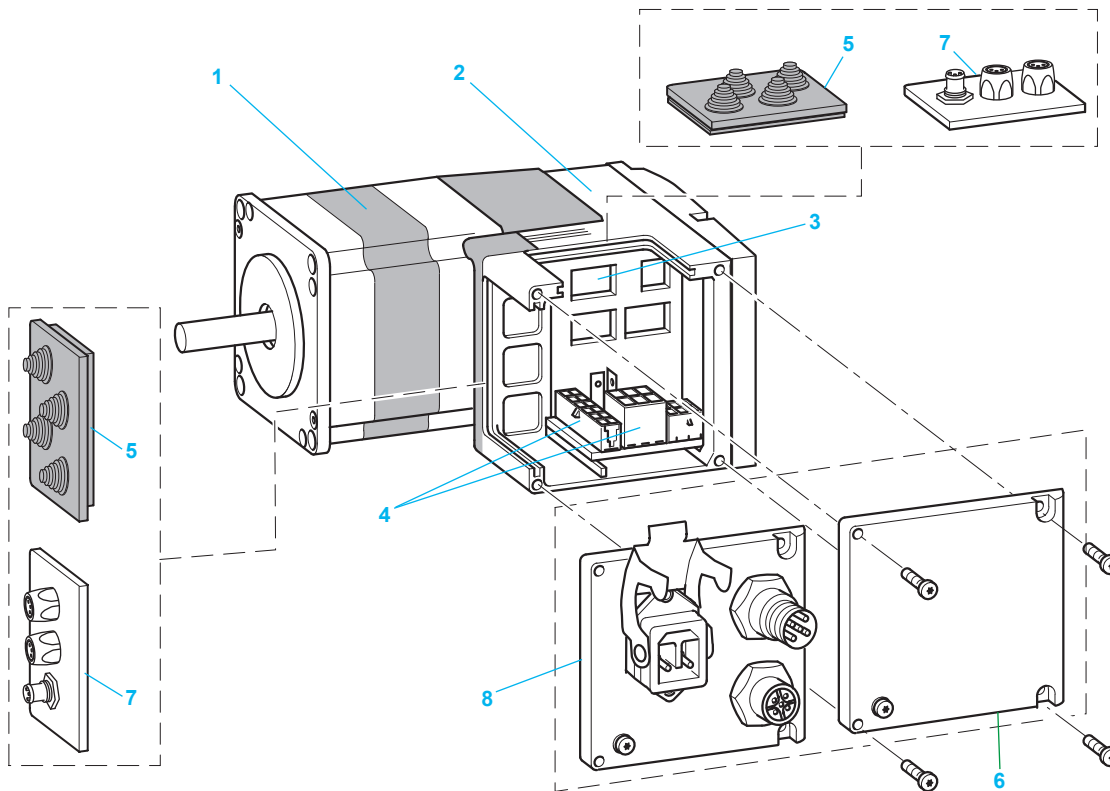

- 1 DC brushless motor
- 2 Electronic unit
- 3 Parameter switch
- 4 Connection terminals

For integrated drive with printed circuit board connector:

- 5 Cable entry plate (see accessories page 36)
- 6 Cover

For integrated drive with industrial connector:

- 7 Plate for connecting I/O and the Safe Torque Off function (see accessories page 38)
- 8 Cover for connecting the 24/48 V $\overline{\text{V}}$ power supply and the communication bus (see accessories page 38)

Note: I/O connection plate equipped with industrial connectors for:

- DeviceNet and Modbus TCP communication bus (1 round connector for IN and OUT signals)
- EtherCAT, EtherNet/IP and Ethernet POWERLINK communication bus: 2 round connectors (1 round connector for each signal, IN and OUT).

Motion control

Lexium integrated drives

IL●2 for DeviceNet, EtherCAT, EtherNet/IP, Modbus TCP, Ethernet POWERLINK
ILE2 with DC brushless motor



ILE2 integrated drive with brushless servo motor

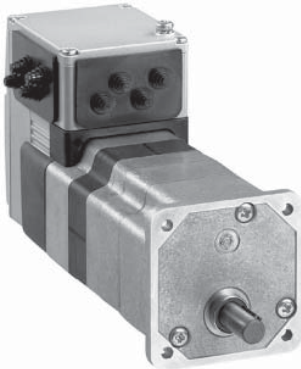

ILE2 integrated drive with brushless servo motor and straight-tooth gearbox

References		I	L	E	2	D	6	6	1	P	B	1	A	1
Example:		I	L	E	2	D	6	6	1	P	B	1	A	1
Motor type E = DC brushless motor		I	L	E	2	D	6	6	1	P	B	1	A	1
Supply voltage 2 = 24...48 V		I	L	E	2	D	6	6	1	P	B	1	A	1
Communication interface D = DeviceNet E = EtherCAT K = EtherNet/IP P = Ethernet POWERLINK T = Modbus TCP		I	L	E	2	D	6	6	1	P	B	1	A	1
Flange size 66 = 66 mm		I	L	E	2	D	6	6	1	P	B	1	A	1
Drive type (1) 1 = ILE2●661 2 = ILE2●662		I	L	E	2	D	6	6	1	P	B	1	A	1
Winding type (1) P = medium rotation speed		I	L	E	2	D	6	6	1	P	B	1	A	1
Connection B = printed circuit board connector C = industrial connector		I	L	E	2	D	6	6	1	P	B	1	A	1
Encoder type 1 = encoder for DC brushless motor (12 points/turn)		I	L	E	2	D	6	6	1	P	B	1	A	1
Holding brake A = without holding brake		I	L	E	2	D	6	6	1	P	B	1	A	1
Gearbox 0 = without gearbox		I	L	E	2	D	6	6	1	P	B	1	A	1
Straight-tooth gearbox (2)														
1 = reduction ratio 18:1 (160:9)														
2 = reduction ratio 38:1 (75:2)														
3 = reduction ratio 54:1 (490:9)														
4 = reduction ratio 115:1 (3675:32)														
Tapered worm gearbox (2)														
5 = reduction ratio 24:1 (525:22)														
6 = reduction ratio 54:1 (1715:32)														
7 = reduction ratio 92:1 (735:5)														
8 = reduction ratio 115:1 (3675:32)														

(1) See the main characteristics and dimensions according to the type of drive in the table below:

Drive		ILE2●661		ILE2●662	
Nominal supply voltage	V $\overline{\text{---}}$	24	48	24	48
Nominal current	A	6.8	3.8	9.5	9.5
Nominal speed of rotation	rpm	4800	6000	3100	5000
Nominal torque	Nm	0.26		0.5	
Maximum torque	Nm	0.43		0.8	
Detent torque (at zero current)	Nm	0.08		0.106	
Dimensions (overall in mm)	Without gearbox	W x H x D	66 x 104 x 122		66 x 104 x 140
	With straight-tooth gearbox	W x H x D	66 x 104 x 174		
	With worm gearbox	W x H x D	66 x 104 x 229		

(2) Gearbox only available for ILE2●661 integrated drive.

Note: See all the data (characteristics, dimensions) on our website www.schneider-electric.com.

Motion control Lexium integrated drives

IL●2 for DeviceNet, EtherCAT, EtherNet/IP,
Modbus TCP, Ethernet POWERLINK
ILS2 with 3-phase stepper motor

Description

ILS2 integrated drives consist of control electronics with an interface for DeviceNet, EtherCAT, EtherNet/IP, Modbus TCP or Ethernet POWERLINK communication bus and a 3-phase stepper motor.

For ILS2●85 integrated drives, an integrated holding brake is also available as an option.

Two types of connection are possible:

- Printed circuit board connectors
- Industrial connectors

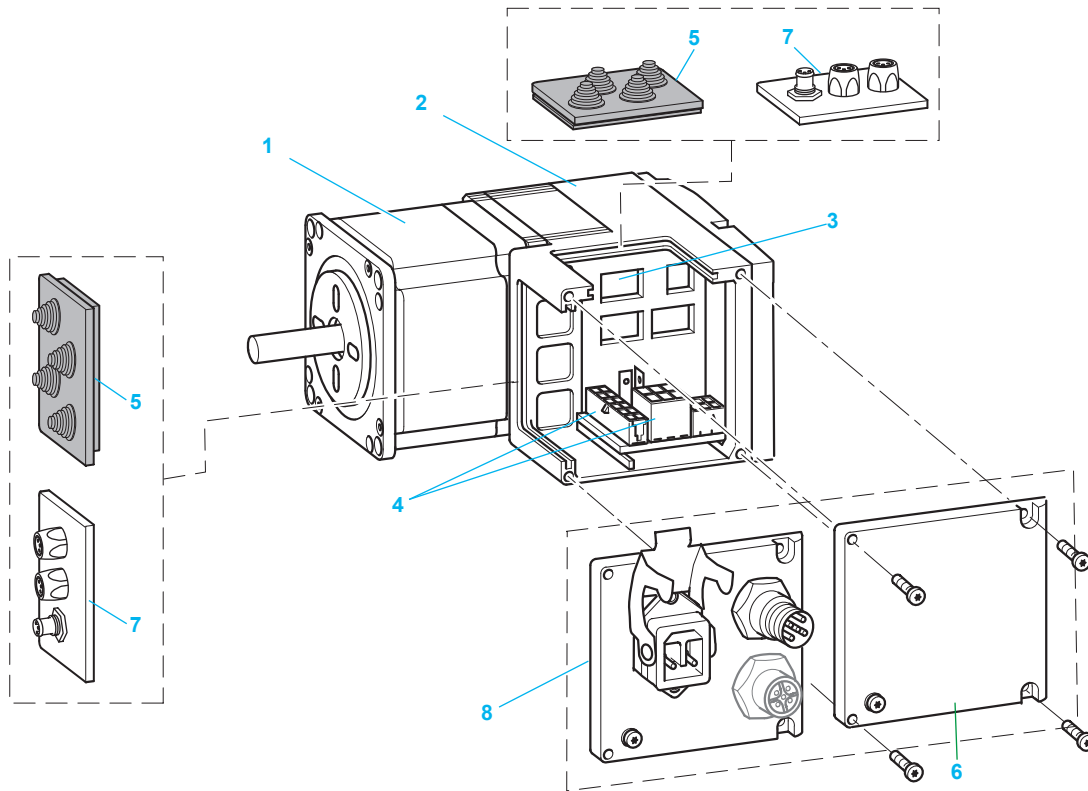

1 3-phase stepper motor

2 Electronic unit

3 Parameter switch

4 Connection terminals

For drive with printed circuit board connector:

5 Cable entry plate (see accessories page 36)

6 Cover

For drive with industrial connector:

7 Plate for connecting I/O and the Safe Torque Off function (see accessories page 38)

8 Cover for connecting the 24/48 V $\overline{\text{V}}$ power supply and the communication bus (see accessories page 38)

Note: I/O connection plate equipped with industrial connectors for:

- DeviceNet and Modbus TCP communication bus (1 round connector for IN and OUT signals)
- EtherCAT, EtherNet/IP and Ethernet POWERLINK communication bus: 2 round connectors (1 round connector for each signal, IN and OUT).

Motion control

Lexium integrated drives

IL●2 for DeviceNet, EtherCAT, EtherNet/IP, Modbus TCP, Ethernet POWERLINK
 ILS2 with 3-phase stepper motor



ILS2 integrated drive with 3-phase stepper motor

References													
Example:	I	L	S	2	D	5	7	1	P	B	1	A	0
Motor type S = 3-phase stepper motor	I	L	S	2	D	5	7	1	P	B	1	A	0
Supply voltage 1 = 24...36 V	I	L	S	2	D	5	7	1	P	B	1	A	0
Communication interface D = DeviceNet E = EtherCAT K = EtherNet/IP P = Ethernet POWERLINK T = Modbus TCP	I	L	S	2	D	5	7	1	P	B	1	A	0
Flange size 57 = 57 mm 85 = 85 mm	I	L	S	2	D	5	7	1	P	B	1	A	0
Drive type (1) 1 = ILS2●●●1 2 = ILS2●●●2 3 = ILS2●●●3	I	L	S	2	D	5	7	1	P	B	1	A	0
Winding type (1) P = medium rotation speed T = high rotation speed (2)	I	L	S	2	D	5	7	1	P	B	1	A	0
Connection B = printed circuit board connector C = industrial connector	I	L	S	2	D	5	7	1	P	B	1	A	0
Sensor type 1 = reference pulse sensor (Zero marker)	I	L	S	2	D	5	7	1	P	B	1	A	0
Holding brake A = without holding brake F = with holding brake (3)	I	L	S	2	D	5	7	1	P	B	1	A	0
Gearbox 0 = without gearbox	I	L	S	2	D	5	7	1	P	B	1	A	0

(1) See the main characteristics and dimensions according to the type of drive in the table below:

Drive		ILS2●571	ILS2●572	ILS2●573	
Winding type		P	P	T	
Nominal speed of rotation	rpm	1100	900	600	
Maximum torque	Nm	0.45	0.9	1.5	
Holding torque	Nm	0.45	0.9	1.5	
Dimensions (overall in mm)	W x H x D	57.2 x 92.2 x 101.9	57.2 x 92.2 x 115.9	57.2 x 92.2 x 138.9	
Drive		ILS2●851	ILS2●852	ILS2●853	
Winding type		P	P	T	P
Nominal speed of rotation	rpm	600	380	200	300
Maximum torque	Nm	2	4	6	4.5
Holding torque	Nm	2	4	6	4.5
Dimensions (overall in mm)	Without holding brake	W x H x D	85 x 119.6 x 140.6	85 x 119.6 x 170.6	85 x 119.6 x 200.6
	With holding brake	W x H x D	85 x 119.6 x 187.3	85 x 119.6 x 217.3	85 x 119.6 x 247.3

(2) Twinding only available for integrated drive with 85 mm flange (ILS2●853).

(3) Holding brake only available for integrated drive with 85 mm flange (ILS2●85).

Note: See all the data (characteristics, dimensions) on our website www.schneider-electric.com.

Motion control

Lexium integrated drives

ILS1 with I/O interface for motion sequence



ILS1 with I/O interface for motion sequence

Presentation

Lexium ILS1 integrated drives with I/O interface for motion sequence consist of a 3-phase stepper motor and control electronics.

ILS1 integrated drives with 3-phase stepper motor provide high torques at low speeds of rotation. They are mainly used in rotation speed mode with excellent stability characteristics and also for high resolution positioning.

The control section consists of control electronics and a power stage. These have a common power supply and are thermally isolated from the motor. They are not electrically isolated.

The integrated drives can operate on a 24 V to 36 V $\overline{\text{V}}$ supply.

Lexium ILS1 integrated drives with I/O interface for motion sequence have numerous interfaces:

- A multifunction interface for selecting up to 16 movement instruction sets
 - An interface for four 24 V signals, configurable as outputs or inputs
 - An RS 485 serial link interface for ease of maintenance
 - An interface for the integrated Safe Torque Off function
- They are wired via a printed circuit board connector.

The commissioning of drives with stepper motor is simple as it does not require any configuration of the control loop.

Instruction sets

Up to 16 instruction sets, containing movement instructions, can be selected and activated directly or sequentially via the logic inputs.

The movement instructions can contain homing commands or positioning instructions. Motion sequences can thus be saved in the drive and controlled via the logic inputs.

The instruction sets are entered and the drive parameters set using the Lexium CT PC software.

Motion control

Lexium integrated drives

ILS1 with I/O interface for motion sequence

Interfaces

Multifunction interface

The multifunction interface is used to select and activate up to 16 instruction sets, containing movement instructions, via the logic inputs.

It is also possible to set the parameters of specific start functions.

RS 485 serial link interface

The RS 485 interface is used to connect an RS 485 serial link during configuration, commissioning or maintenance.

It is used to connect the Lexium CT PC software with a direct link, via an RS 485/USB converter, to access the fault log, temperature control and various other functions.

Interface for 24 V signals

Four 24 V signals are available, configurable as inputs or outputs via the parameter switch.

They can also be used to set the parameters of functions such as limit switch detection.

They can be used by the master controller.

The 24 V power for the outputs is provided internally via the integrated drive's power supply.

Interface for Safe Torque Off (Power Removal) safety function

The Safe Torque Off (Power Removal) safety function enables a category 0 or 1 stop to be performed in accordance with standard IEC/EN 60204-1 and/or prevents unintended motor operation in accordance with standard IEC/EN 61508 level SIL2, ISO 13849-1 performance level "d" (PL d) and IEC/EN 61800-5-2 (STO).

No additional power protection option is necessary. The Lexium ILS1 integrated drive can remain powered up, which reduces the system costs and the restart time.

The Safe Torque Off function is activated via two redundant 24 V input signals (active in OFF state).

Special technical features

- High continuous stall torque
- Good speed stability characteristics
- High encoder accuracy (0.018°)
- Integrated holding brake available as an option for ILS1M85 integrated drive
- Planetary gearbox available as an option

Motion control

Lexium integrated drives

ILS1 with I/O interface for motion sequence

“Motion sequence” operating mode

Presentation

In “Motion sequence” operating mode, up to 16 movement instruction sets can be activated directly or sequentially via the logic input signals. The movement instructions can contain homing or positioning parameters. A motion sequence can thus be saved in the drive and controlled via the logic input signals.

The instruction sets are entered and the drive parameters set using the “Lexium CT” PC commissioning software.

Direct selection of movement instructions

Direct selection of movement instructions is used when a master controller is controlling the sequencing of the various instruction sets. The instruction set to be processed is selected and activated via the logic inputs.

Sequential selection of movement instructions

Sequential selection of movement instructions is used for processing simple motion sequences. Instruction sets are sequenced by entering a waiting time, a transition condition and the next instruction set.

Example of a transition condition: rising edge on the START logic input.

A motion sequence can also be executed cyclically, with or without return to the initial position.

Processing status of a movement instruction

The status of the movement instruction is indicated via the Handshake output. It is also possible to indicate an internal processing status such as “Drive in motion” via an additional output signal.

Selection of the motion profile

Speeds and accelerations are saved in motion profiles. The movement instruction set contains the list of motion profiles.

Other operating modes

Other operating modes can be set via the communication bus:

- Manual (JOG)
- Point-to-point
- Homing

Motion control

Lexium integrated drives

ILS1 with I/O interface for motion sequence



Integrated drive with printed circuit board connectors

Connection

Lexium ILS1 integrated drives are connected via printed circuit board connectors.

Printed circuit board connectors

Printed circuit board connectors are used to connect the multifunction interface, the RS 485 serial link, the interface for 24 V signals and the Safe Torque Off function, as well as the power supply.

The integrated drive is connected via two cable entry plates, to be ordered separately (see accessories page 36).

Compliance with international standards and certifications

The Lexium integrated drives offer has been developed in accordance with strict international standards and recommendations for variable speed electrical power drive products, in particular IEC/EN 61800-3 (immunity to disturbance related to high frequency signals transmitted along cables) and IEC/EN 50178 (vibration resistance).

Compliance with electromagnetic compatibility requirements has been incorporated in the design of the integrated drive. The entire range conforms to international standard IEC/EN 61800-3:2001, environment 2.

The integrated drives carry the CE mark in accordance with the European machinery directive (98/37/EEC) and the European EMC directive (2004/108/EEC).

The entire range is cULus certified (United States and Canada).

It is also TÜV certified in accordance with the safety standards for medical devices and equipment. This certification covers:

- Functional safety of electrical/electronic/programmable electronic safety-related systems (IEC 61508: 2000; SIL 2)
- Safety of machinery – functional safety of safety-related electrical, electronic and programmable electronic control systems (IEC 62061: 2005; SILcl2)
- Safety of machinery – safety-related parts of electronic control systems – part 1: General principles for design (ISO 13849-1: 2006; PL d (category 3))

Motion control

Lexium integrated drives

ILS1 with I/O interface for motion sequence
ILS1 with 3-phase stepper motor

Description

Lexium ILS1 integrated drives with I/O interface for motion sequence consist of control electronics and a 3-phase stepper motor. They are available with printed circuit board connectors. For ILS1M85 drives, an integrated holding brake is available as an option.

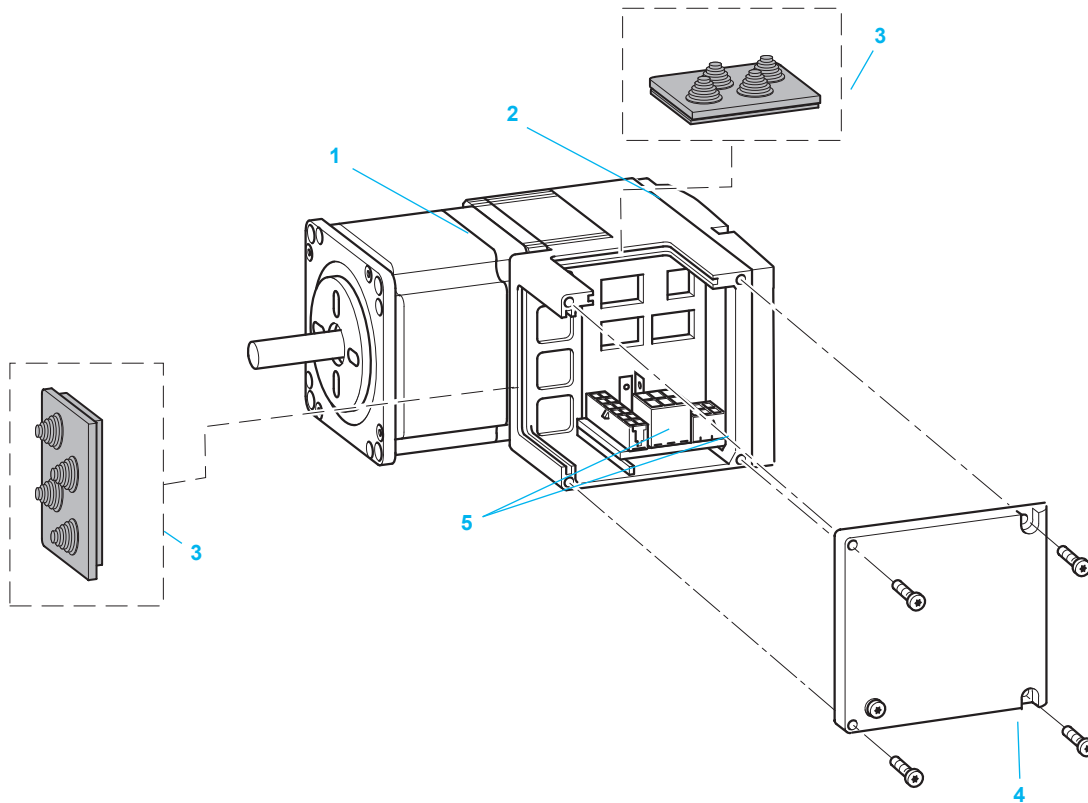

- 1 3-phase stepper motor
- 2 Electronic unit
- 3 Cable entry plate (see accessories page 36)
- 4 Cover
- 5 Connection terminals

Motion control

Lexium integrated drives

ILS1 with I/O interface for motion sequence
ILS1 with 3-phase stepper motor



ILS1 integrated drive with I/O interface for motion sequence

References													
Example:	I	L	S	1	M	5	7	1	P	B	1	A	0
Motor type S = 3-phase stepper motor	I	L	S	1	M	5	7	1	P	B	1	A	0
Supply voltage 1 = 24...36 V	I	L	S	1	M	5	7	1	P	B	1	A	0
Interface M = I/O interface for motion sequence	I	L	S	1	M	5	7	1	P	B	1	A	0
Flange size 57 = 57 mm 85 = 85 mm	I	L	S	1	M	5	7	1	P	B	1	A	0
Drive type (1) 1 = ILS1M●●1 2 = ILS1M●●2 3 = ILS1M●●3	I	L	S	1	M	5	7	1	P	B	1	A	0
Winding type (1) P = medium rotation speed T = high rotation speed (2)	I	L	S	1	M	5	7	1	P	B	1	A	0
Connection B = printed circuit board connector	I	L	S	1	M	5	7	1	P	B	1	A	0
Sensor type 1 = reference pulse sensor (Zero marker)	I	L	S	1	M	5	7	1	P	B	1	A	0
Holding brake A = without holding brake F = with holding brake (3)	I	L	S	1	M	5	7	1	P	B	1	A	0
Gearbox 0 = without gearbox	I	L	S	1	M	5	7	1	P	B	1	A	0

(1) See the main characteristics and dimensions according to the type of drive in the table below:

Drive		ILS1M571	ILS1M572	ILS1M573	
Winding type		P	P	P	
Nominal speed of rotation	rpm	1000	600	450	
Maximum torque	Nm	0.45	0.9	1.5	
Holding torque	Nm	0.51	1.02	1.7	
Dimensions (overall in mm)	W x H x D	57.2 x 92.2 x 101.9	57.2 x 92.2 x 115.9	57.2 x 92.2 x 138.9	
Drive		ILS1M851	ILS1M852	ILS1M853	
Winding type		P	P	P	T
Nominal speed of rotation	rpm	450	200	120	300
Maximum torque	Nm	2	4	6	4.5
Holding torque	Nm	2	4	6	4.5
Dimensions (overall in mm)	Without holding brake	W x H x D	85 x 119.6 x 140.6	85 x 119.6 x 170.6	85 x 119.6 x 200.6
	With holding brake	W x H x D	85 x 119.6 x 187.3	85 x 119.6 x 217.3	85 x 119.6 x 247.3

(2) Twinding only available for integrated drive with 85 mm flange (ILS1M853).

(3) Holding brake only available for integrated drive with 85 mm flange (ILS1M85).

Note: See all the data (characteristics, dimensions) on our website www.schneider-electric.com.

Motion control

Lexium integrated drives

ILS1 with pulse/direction (P/D) interface



ILS1 with pulse/direction (P/D) interface

Presentation

ILS1 integrated drives consist of a 3-phase stepper motor and control electronics with pulse/direction (P/D) interface. The pulse/direction (P/D) signals from a master controller, for example a Lexium Controller, or the A/B signals from an encoder are converted directly into a movement.

ILS1 integrated drives with 3-phase stepper motor provide high torques at low speeds of rotation. They are mainly used in rotation speed mode with excellent speed stability characteristics and also for high resolution positioning.

The control section consists of control electronics and a power stage which have a common power supply and are thermally insulated from the motor. They are not electrically isolated.

ILS1 integrated drives can operate on a 24 V to 36 V $\bar{\text{~}}$ supply.

ILS1 integrated drives control the stepper motor according to a reference value. This reference value is sent to the multifunction interface by a master controller or an external master encoder.

The number of steps per turn is set via the parameter switch.

ILS1 integrated drives with pulse/direction (P/D) interface have numerous interfaces:

- A multifunction interface
- An interface for four 24 V signals
- An RS 485 serial link interface
- An interface for the integrated Safe Torque Off function

They are wired via a printed circuit board connector.

The commissioning of ILS1 drives with stepper motor is simple as it does not require any configuration of the control loop.

Interfaces

Multifunction interface

The multifunction interface takes one of the following signals, depending on the integrated drive model:

- 24 V signals separated by optical coupler (ILS1U)
- 5 V signals separated by optical coupler (ILS1V)
- 5 V differential signals without electrical isolation (ILS1W)

The reference values are sent via two signals, either as pulse/direction (P/D) signals, or as type A/B encoder signals.

The other signals have the following functions:

- "Activation/locking of the power stage and activation/locking of the indexing pulse"
- "Setting the number of steps/setting the motor phase current"

RS 485 serial link interface

The RS 485 signal interface is used to connect an RS 485 serial link during configuration, commissioning or maintenance.

It is used to connect the Lexium CT PC software with a direct link, via an RS 485/RS 232 or RS 485/USB converter, to access the fault log, temperature control and various other functions.

Interface for 24 V signals

Two input signals and two output signals are available.

The input signals have the following functions:

- "Setting the number of steps"
- "Activation and locking of the power stage/activation and locking of the indexing pulse"

The output signals have the following functions:

- "Drive ready"
- "Display a fault/indexing pulse"

The 24 V power for the outputs is provided internally via the integrated drive's power supply.

Motion control

Lexium integrated drives

ILS1 with pulse/direction (P/D) interface

Interfaces (continued)

Interface for Safe Torque Off (Power Removal) safety function

The Safe Torque Off (Power Removal) safety function enables a category 0 or 1 stop to be performed in accordance with standard IEC/EN 60204-1 and/or prevents unintended motor operation in accordance with standard IEC/EN 61508 level SIL2, ISO 13849-1 performance level “d” (PL d) and IEC/EN 61800-5-2 (STO).

No additional power protection option is necessary. The Lexium ILS1 integrated drive can remain powered up, which reduces the system costs and the restart time.

The Safe Torque Off function is activated via two redundant 24 V input signals (active in OFF state).

Special technical features

- High continuous stall torque
- Good speed stability characteristics
- High encoder accuracy (0.018°)
- Integrated holding brake available as an option for the ILS1●85 integrated drive
- Planetary gearbox available as an option

Connection

Lexium ILS integrated drives are connected via printed circuit board connectors.

Printed circuit board connectors

Printed circuit board connectors are used to connect the multifunction interface, the RS 485 serial link, the interface for 24 V signals and the Safe Torque Off function, as well as the power supply.

The integrated drive is connected via two plates for cable entry plates, to be ordered separately (see accessories page 36).

Main functions

Configuration by parameter switch

The following functions can be set on ILS1 integrated drives via the parameter switch:

- Number of steps
- Motor phase current
- Reduction of motor phase current
- Input signal functions:
 - Transmission of the reference value via pulse/direction (PULSE/DIR) or encoder (A/B) signals
 - Activation/locking of the power stage (ENABLE/GATE input signal)
 - Activation/locking of the indexing pulse (ENABLE/GATE input signal)
 - Modulation of the motor phase current via a PWM signal (PWM/STEP2_INV input signal)
 - Increase/decrease the number of steps by a factor of 10 (PWM/STEP2_INV input signal)
- Output signal functions:
 - Display a fault (FAULT/INDEXPULSE output signal)
 - Indexing pulse signal (FAULT/INDEXPULSE output signal)
 - “Drive ready” signal (ACTIVE output signal)
- Blocking detection
- Activation of the RS 485 line terminator
- Activation/deactivation of the Safe Torque Off function

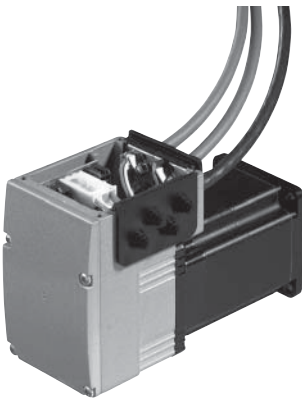

Integrated drive with printed circuit board connectors

Motion control

Lexium integrated drives

ILS1 with pulse/direction (P/D) interface
ILS1 with 3-phase stepper motor

Description

ILS1 integrated drives consist of control electronics with pulse/direction (P/D) interface and a 3-phase stepper motor. They are available with printed circuit board connectors. For ILS1M85 integrated drives, an integrated holding brake is available as an option.

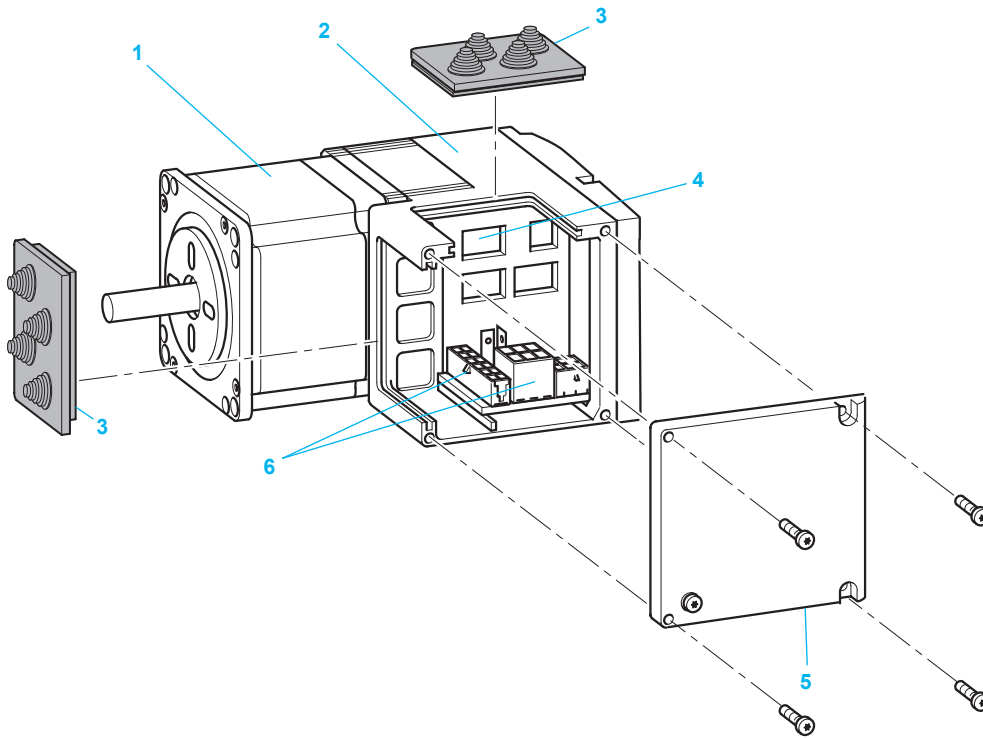

- 1 3-phase stepper motor
- 2 Electronic unit
- 3 Cable entry plate (see accessories page 36)
- 4 Parameter switch
- 5 Cover
- 6 Connection terminals

Motion control

Lexium integrated drives

ILS1 with pulse/direction (P/D) interface
 ILS1 with 3-phase stepper motor



ILS1 integrated drive with pulse/direction interface

References													
Example:	I	L	S	1	U	5	7	1	P	B	1	A	0
Motor type S = 3-phase stepper motor	I	L	S	1	U	5	7	1	P	B	1	A	0
Supply voltage 1 = 24...36 V	I	L	S	1	U	5	7	1	P	B	1	A	0
Interface U = 24 V pulse/direction signals, separated by optical coupler V = 5 V pulse/direction signals, separated by optical coupler W = 5 V pulse/direction signals, RS 422	I	L	S	1	U	5	7	1	P	B	1	A	0
Flange size 57 = 57 mm 85 = 85 mm	I	L	S	1	U	5	7	1	P	B	1	A	0
Drive type (1) 1 = ILS1●●●1 2 = ILS1●●●2 3 = ILS1●●●3	I	L	S	1	U	5	7	1	P	B	1	A	0
Winding type P = medium rotation speed T = high rotation speed (2)	I	L	S	1	U	5	7	1	P	B	1	A	0
Connection B = printed circuit board connector	I	L	S	1	U	5	7	1	P	B	1	A	0
Sensor type 1 = reference pulse sensor (Zero marker)	I	L	S	1	U	5	7	1	P	B	1	A	0
Holding brake A = without holding brake F = with holding brake (3)	I	L	S	1	U	5	7	1	P	B	1	A	0
Gearbox 0 = without gearbox	I	L	S	1	U	5	7	1	P	B	1	A	0

(1) See the main characteristics and dimensions according to the type of drive in the table below:

Drive		ILS1●571	ILS1●572	ILS1●573	
Winding type		P	P	P	
Nominal speed of rotation	rpm	1000	600	450	
Maximum torque	Nm	0.45	0.9	1.5	
Holding torque	Nm	0.51	1.02	1.7	
Dimensions (overall in mm)	W x H x D	57.2 x 92.2 x 101.9	57.2 x 92.2 x 115.9	57.2 x 92.2 x 138.9	
Drive		ILS1●851	ILS1●852	ILS1●853	
Winding type		P	P	P	T
Nominal speed of rotation	rpm	450	200	120	300
Maximum torque	Nm	2	4	6	4.5
Holding torque	Nm	2	4	6	4.5
Dimensions (overall in mm)	Without holding brake	W x H x D	85 x 119.6 x 140.6	85 x 119.6 x 170.6	85 x 119.6 x 200.6
	With holding brake	W x H x D	85 x 119.6 x 187.3	85 x 119.6 x 217.3	85 x 119.6 x 247.3

(2) Twinding only available for integrated drive with 85 mm flange (ILS1●853).

(3) Holding brake only available for integrated drive with 85 mm flange (ILS1●85).

Note: See all the data (characteristics, dimensions) on our website www.schneider-electric.com.

Motion control Lexium integrated drives

Accessories for ILA, ILE and ILS
integrated drives



IP 54 sealing plate VW3L10000N●●



Kit with plate for cable entries and sealing plate VW3L10222



Kit for RS 485 serial link connection VW3L1R000



Plates with cable entries VW3L10100N●

Installation accessories

Description	Order in lots of	Unit reference	Weight kg
IP 54 sealing plates			
Sealing plates	10	VW3L10000N10	–
2 plates are required per integrated drive	20	VW3L10000N20	–
	50	VW3L10000N50	–

Kit with cable entry plate and IP 54 sealing plate

Kit comprising: <ul style="list-style-type: none"> ■ 1 plate with two M16 cable entries for 2 cables diameter 5 to 9 mm ■ One IP 54 sealing plate 	–	VW3L10222	–
--	---	-----------	---

Installation kit

Installation kit for connecting the communication bus, the power supply and the Safe Torque Off function. Consists of a cable entry plate, crimp contacts, crimp connectors, connector housings and shielding film.	–	VW3L10111	–
--	---	-----------	---

Kit for RS 485 serial link connection (commissioning)

Kit comprising: <ul style="list-style-type: none"> ■ 1 plate equipped with: <ul style="list-style-type: none"> □ One M12 female connector (5-way) □ One M12 male connector (5-way) ■ One IP 54 sealing plate 	–	VW3L1R000	–
--	---	-----------	---

Additional accessory

Set of connectors (CANopen/RS 485)	–	VW3L5F000	–
------------------------------------	---	-----------	---

Cordsets for RS 485 serial link connection (commissioning)

Description	Length m	Unit reference	Weight kg
Preassembled cordset with: <ul style="list-style-type: none"> ■ Integrated drive end: 1 connector for RS 485 serial link ■ Other end: flying leads 	3	VW3L1R000R30	–
Preassembled cordset with: <ul style="list-style-type: none"> ■ Integrated drive end: 1 connector for RS 485 serial link ■ Other end: 1 RJ45 connector for RJ45/USB cable TCSMCNAM3M002P (commissioning via a PC) 	3	VW3L1T000R30	–

Accessories for integrated drives with printed circuit board connectors

Plates with cable entries

Description	Order in lots of	Unit reference	Weight kg
Plates	2	VW3L10100N2	–
for 4 cables diameter 3 to 9 mm. 2 plates are required per integrated drive. They provide the seal, the mechanical catch and connection of the shielding.	10	VW3L10100N10	–

Motion control

Lexium integrated drives

Accessories for ILS, ILE and ILS integrated drives

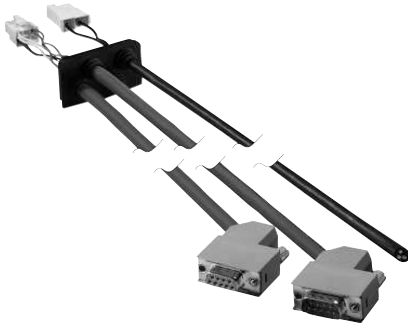

Cordset for interfaces for communication bus and power supply VW3L2001R30



Cordset for ILS1 integrated drives with I/O interface VW3L2M001R00



Cordset for ILS1 integrated drives with I/O interface and plate for I/O and safety signals VW3L2M211R00

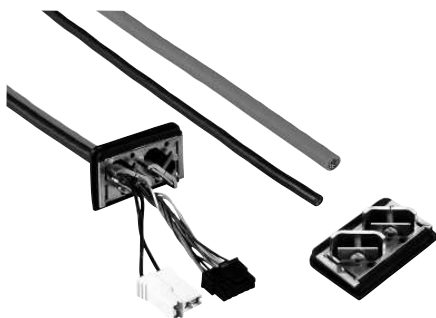

Cordset for ILS1 integrated drive with pulse/direction interface VW3L2U001R00

Accessories for integrated drives with printed circuit board connectors (continued)

Cordsets for Safe Torque Off signals

Description	For use with	Length m	Unit reference	Weight kg
Preassembled cordsets with:		3	VW3L20010R30	–
■ Integrated drive end:		5	VW3L20010R50	–
1 connector for Safe Torque Off function		10	VW3L20010R100	–
■ Other end: flying leads		15	VW3L20010R150	–
		20	VW3L20010R200	–

Cordsets for communication bus interfaces (CANopen, PROFIBUS DP, RS 485, DeviceNet) and power supply

Preassembled cordsets with:	CANopen	3	VW3L2F001R30	–
■ Integrated drive end: cable entry and mechanical catch.	PROFIBUS DP	3	VW3L2B001R30	–
For power supply and communication bus.	RS 485	3	VW3L2R001R30	–
■ Other end: flying leads for power supply and 9-way SUB-D connector for communication bus.	DeviceNet	3	VW3L2D001R30	–

Cordsets for communication bus interfaces (EtherCAT, EtherNet/IP, Modbus TCP, Ethernet POWERLINK) and power supply

Preassembled cordsets with:	EtherCAT	3	VW3L2E001R30	–
■ Integrated drive end: cable entry and mechanical catch.	EtherNet/IP	3	VW3L2K001R30	–
For power supply and communication bus.	Modbus TCP	3	VW3L2T001R30	–
■ Other end:	EtherNet	3	VW3L2P001R30	–
□ flying leads for power supply	POWERLINK			
□ RJ45 connector for communication bus				

Cordsets for ILS1 integrated drives with I/O interface for motion sequence

Preassembled cordsets with:		3	VW3L2M001R30	–
■ Integrated drive end: plate with cable entry and mechanical catch for control via data sets.		5	VW3L2M001R50	–
For power supply and I/O signals.		10	VW3L2M001R100	–
■ Other end: flying leads		15	VW3L2M001R150	–
		20	VW3L2M001R200	–

Cordsets for ILS1 integrated drives with I/O interface for motion sequence and plate for I/O signals and Safe Torque Off signals

Preassembled cordsets with:		3	VW3L2M211R30	–
■ Integrated drive end: plate with cable entry and mechanical catch for control via data sets.		5	VW3L2M211R50	–
For power supply and I/O signals.		10	VW3L2M211R100	–
■ Other end: flying leads		15	VW3L2M211R150	–
Additional plate equipped with:		20	VW3L2M211R200	–
■ Two connectors for I/O signals				
■ One M8 connector for Safe Torque Off signals				

Cordsets for ILS1 integrated drives with pulse/direction (P/D) interface

Preassembled cordsets with:		3	VW3L2U001R30	–
■ Integrated drive end: plate with cable entry and mechanical catch.		5	VW3L2U001R50	–
For power supply and pulse/direction (P/D) or A/B encoder signals.		10	VW3L2U001R100	–
■ Other end: flying leads		15	VW3L2U001R150	–
		20	VW3L2U001R200	–

Motion control

Lexium integrated drives

Accessories for ILA, ILE and ILS integrated drives



Kit for I/O signals VW3L40300



Kit for I/O signals and Safe Torque Off signals VW3L40210



Kit for I/O signals and Safe Torque Off signals VW3L40420



Cordsets for Safe Torque Off signals VW3L30010R

Accessories for integrated drives with industrial connectors

Description	Reference	Weight kg
Cover for connecting the power supply and the communication bus		
Cover for connecting the power supply and the communication bus:		
PROFIBUS DP	VW3L1B001N01	—
DeviceNet	VW3L1D001N01	—
EtherNet/IP, EtherCAT, EtherNet POWERLINK	VW3L1E001N01	—
CANopen	VW3L1F001N01	—
Modbus TCP	VW3L1T001N01	—
RS 485	VW3L1R001N01	—

Kit for I/O signals

Kit comprising:	VW3L40300	—
■ One plate equipped with three M8 female connectors (3-way) for I/O signals		
■ One IP 54 sealing plate		

Additional accessory

Set of 3 connectors for connecting I/O	VW3L50300	—
--	-----------	---

Kit for Safe Torque Off signals

Kit comprising:	VW3L40020	—
■ One plate equipped with one male and one female M8 connector (4-way) for two Safe Torque Off signals		
■ One IP 54 sealing plate		

Additional accessory

Cordsets (M8x4) for Safe Torque Off signals (see below for full references)	VW3L30010R	—
---	------------	---

Kit for I/O signals and Safe Torque Off signals

Kit comprising:	VW3L40210	—
■ One plate equipped with:		
□ Two M8 female connectors (3-way) for I/O signals		
□ One M8 male connector (4-way) for Safe Torque Off signals		
■ One IP 54 sealing plate		

Kit comprising:	VW3L40420	—
■ One plate equipped with:		
□ Two M8 female connectors (3-way) for I/O signals		
□ One M8 male connector (4-way) for Safe Torque Off signals		
■ One plate equipped with:		
□ Two M8 female connectors (3-way) for I/O signals		
□ One M8 female connector (4-way) for Safe Torque Off signals		

Additional accessories

Set of 2 connectors for I/O	VW3L50200	—
Connector for Safe Torque Off signals	VW3L50010	—
Cordset (M8x4) for Safe Torque Off signals (see below for full references)	VW3L30010R	—

Cordsets for Safe Torque Off signals

Description	Length m	Reference	Weight kg
Cordsets equipped with one M8 female connector (4-way) for connecting Safe Torque Off signals	3	VW3L30010R30	—
	5	VW3L30010R50	—
	10	VW3L30010R100	—
	15	VW3L30010R150	—
	20	VW3L30010R200	—

Motion control

Lexium integrated drives

Accessories for ILA, ILE and ILS integrated drives



Power cordsets VW3L30001R●●



Connector for Safe Torque Off signals VW3L50010



Set of connectors for I/O signals VW3L50200



Set of connectors for EtherCAT bus VW3L5E000



Connector for DeviceNet bus VW3L5D000

Accessories for integrated drives with industrial connectors (continued)

Description	Length m	Reference	Weight kg
Power cordsets			
Preassembled cordsets with:	3	VW3L30001R30	–
■ Integrated drive end: 1 connector for power supply	5	VW3L30001R50	–
■ Other end: flying leads	10	VW3L30001R100	–
DESINA compliant	15	VW3L30001R150	–
	20	VW3L30001R200	–

Connector for Safe Torque Off signals

Connector, M8 round (4-way) for creating cordsets for Safe Torque Off signals	VW3L50010	–
--	-----------	---

Set of 2 connectors for I/O signals

Set consisting of:	VW3L50200	–
■ Two M8 round connectors (3-way)		

Set of 3 connectors for I/O signals

Set consisting of:	VW3L50300	–
■ Three M8 round connectors (3-way)		

Set of CANopen/RS 485 connectors for IL●1 integrated drives

Set consisting of:	VW3L5F000	–
■ One M12 round male connector (A-coded)		
■ One M12 round female connector (A-coded)		
■ One M12 blanking plug		

Set of PROFIBUS DP connectors for IL●1 integrated drives

Set consisting of:	VW3L5B000	–
■ One M12 round male connector (B-coded)		
■ One M12 round female connector (B-coded)		
■ One M12 blanking plug		

Set of EtherCAT connectors

Set consisting of:	VW3L5E000	–
■ Two M12 round male connectors (4-way), (D-coded)		
■ One M12 blanking plug		

Set of EtherNet/IP connectors

Set consisting of:	VW3L5K000	–
■ Two M12 round male connectors (4-way), (D-coded)		
■ One M12 blanking plug		

Set of Ethernet POWERLINK connectors

Set consisting of:	VW3L5P000	–
■ Two M12 round male connectors (4-way), (D-coded)		
■ One M12 blanking plug		

DeviceNet connector

Female connector, M12 DeviceNet (5-way), (A-coded)	VW3L5D000	–
--	-----------	---

Modbus TCP connector

Female connector, M12 Modbus TCP (4-way), (D-coded)	VW3L5T000	–
---	-----------	---

Motion control

Lexium integrated drives

Option: GB● planetary gearboxes



GBX planetary gearbox



GBY angular planetary gearbox



GBK adaptor kit

Presentation

In many cases, motion control requires the use of a planetary gearbox to adapt speeds of rotation and torques, while providing the precision demanded by the application.

To meet these requirements, Schneider Electric has chosen to use Neugart GBX planetary gearboxes and GBY angular planetary gearboxes which are ideal for integrated drives. These gearboxes are lubricated for life and are easy to install and operate.

Combining integrated drives with the most appropriate planetary gearboxes makes them very easy to mount and ensures simple, risk-free operation.

The gearboxes are designed for applications which are not susceptible to mechanical backlash. They have a keyed shaft, are lubricated for life and conform to IP 54 degree of protection.

GBX planetary gearboxes are available in three sizes (GBX 40, GBX 60, GBX 80) with 11 reduction ratios (3:1 ... 40:1).

GBY angular planetary gearboxes are available in two sizes (GBY 60, GBY 80) with 7 reduction ratios.

A GBK adaptor kit is also offered for assembling the integrated drive and the GB● planetary gearbox (see page 43).

It comprises:

- An adaptor plate
- A shaft end adaptor, depending on the model (depends on the integrated drive/ planetary gearbox combination)
- Fixing accessories for mounting the plate on the planetary gearbox
- Fixing accessories for mounting the integrated drive

The tables on pages 41 and 42 give the most appropriate integrated drive/gearbox combinations.

For other combinations or any additional information about the characteristics of the integrated drives, see the integrated drive data sheets or our website www.schneider-electric.com.

Motion control

Lexium integrated drives

Option: GBX planetary gearboxes

References

PF090936



GBX planetary gearbox

Size	Reduction ratio	Reference (1)	Weight kg
GBX 40	3:1, 5:1 and 8:1	GBX 040 ●●● K	0.350
GBX 60	3:1, 4:1, 5:1 and 8:1	GBX 060 ●●● K	0.900
	9:1, 12:1, 15:1, 16:1, 20:1, 25:1 and 40:1	GBX 060 ●●● K	1.100
GBX 80	3:1, 4:1, 5:1 and 8:1	GBX 080 ●●● K	2.100
	9:1, 12:1, 15:1, 16:1, 20:1 and 25:1	GBX 080 ●●● K	2.600

(1) To order a GBY angular planetary gearbox, complete each of the above references as follows:

		GBX				●●●	●●●	K
Size	Housing diameter	40 mm	040					
		60 mm	060					
		80 mm	080					
Reduction ratio		3:1			003			
		5:1			005			
		8:1			008			
		9:1			009			
		12:1			012			
		15:1			015			
		16:1			016			
		20:1			020			
		25:1			025			
		40:1			040			
Mounting with GBK adaptor kit (see page 43)								K

Integrated drive/GBX planetary gearbox combinations

Reduction ratios from 3:1 to 40:1

Type of integrated drive	Reduction ratio										
	3:1	4:1	5:1	8:1	9:1	12:1	15:1	16:1	20:1	25:1	40:1
ILA1●571T	GBX 60	GBX 60	GBX 60	GBX 60	GBX 60	GBX 60	GBX 60	GBX 60	GBX 60	GBX 60	GBX 60
ILA1●571P	GBX 60	GBX 60	GBX 60	GBX 60	GBX 60	GBX 60	GBX 60	GBX 60	GBX 60	GBX 60	GBX 60
ILA1●572T	GBX 60	GBX 60	GBX 60	GBX 60	GBX 60	GBX 60	GBX 60	GBX 60	GBX 60	GBX 60	GBX 60
ILA1●572P	GBX 60	GBX 60	GBX 60	GBX 60	GBX 60	GBX 60	GBX 60	GBX 60	GBX 60	GBX 60	GBX 60
ILA2●571T	GBX 60	GBX 60	GBX 60	GBX 60	GBX 60	GBX 60	GBX 60	GBX 60	GBX 60	GBX 60	GBX 60
ILA2●571P	GBX 60	GBX 60	GBX 60	GBX 60	GBX 60	GBX 60	GBX 60	GBX 60	GBX 60	GBX 60	GBX 60
ILA2●572T	GBX 60	GBX 60	GBX 60	GBX 60	GBX 60	GBX 60	GBX 60	GBX 60	GBX 60	GBX 60	GBX 60
ILA2●572P	GBX 60	GBX 60	GBX 60	GBX 60	GBX 60	GBX 60	GBX 60	GBX 60	GBX 60	GBX 60	GBX 60
ILE1●661P	GBX 40	–	GBX 40	GBX 40	GBX 60	GBX 60	GBX 60	GBX 60	GBX 60	GBX 60	GBX 60
ILE2●661P	GBX 40	–	GBX 40	GBX 40	GBX 60	GBX 60	GBX 60	GBX 60	GBX 60	GBX 60	GBX 60
ILE2●662P	GBX 40	–	GBX 40	GBX 40	GBX 60	GBX 60	GBX 60	GBX 60	GBX 60	GBX 60	GBX 60
ILS1●571P	GBX 60	GBX 60	GBX 60	GBX 60	GBX 60	GBX 60	GBX 60	GBX 60	GBX 60	GBX 60	GBX 60
ILS1●572P	GBX 60	GBX 60	GBX 60	GBX 60	GBX 60	GBX 60	GBX 60	GBX 60	GBX 60	GBX 60	GBX 60
ILS1●573P	GBX 60	GBX 60	GBX 60	GBX 60	GBX 60	GBX 60	GBX 60	GBX 60	GBX 60	GBX 60	GBX 60
ILS1●851P	GBX 80	GBX 80	GBX 80	GBX 80	GBX 80	GBX 80	GBX 80	GBX 80	GBX 80	GBX 80	–
ILS1●852P	GBX 80	GBX 80	GBX 80	GBX 80	GBX 80	GBX 80	GBX 80	GBX 80	GBX 80	GBX 80	–
ILS1●853P	GBX 80	GBX 80	GBX 80	GBX 80	GBX 80	GBX 80	GBX 80	GBX 80	GBX 80	GBX 80	–
ILS1●853T	GBX 80	GBX 80	GBX 80	GBX 80	GBX 80	GBX 80	GBX 80	GBX 80	GBX 80	GBX 80	–
ILS2●571P	GBX 60	GBX 60	GBX 60	GBX 60	GBX 60	GBX 60	GBX 60	GBX 60	GBX 60	GBX 60	GBX 60
ILS2●572P	GBX 60	GBX 60	GBX 60	GBX 60	GBX 60	GBX 60	GBX 60	GBX 60	GBX 60	GBX 60	GBX 60
ILS2●573P	GBX 60	GBX 60	GBX 60	GBX 60	GBX 60	GBX 60	GBX 60	GBX 60	GBX 60	GBX 60	GBX 60
ILS2●851P	GBX 80	GBX 80	GBX 80	GBX 80	GBX 80	GBX 80	GBX 80	GBX 80	GBX 80	GBX 80	–
ILS2●852P	GBX 80	GBX 80	GBX 80	GBX 80	GBX 80	GBX 80	GBX 80	GBX 80	GBX 80	GBX 80	–
ILS2●853P	GBX 80	GBX 80	GBX 80	GBX 80	GBX 80	GBX 80	GBX 80	GBX 80	GBX 80	GBX 80	–
ILS2●853T	GBX 80	GBX 80	GBX 80	GBX 80	GBX 80	GBX 80	GBX 80	GBX 80	GBX 80	GBX 80	–

GBX 60 For this combination, you must check that the application will not exceed the maximum gearbox output torque (see the values on our website www.schneider-electric.com).

Motion control

Lexium integrated drives

Option: GBY planetary gearboxes

References

PF080937



GBY angular planetary gearbox

Size	Reduction ratio	Reference (1)	Weight kg
GBY 60	3:1, 4:1, 5:1 and 8:1	GBY 060●●● K	4.400
	12:1, 20:1 and 40:1	GBY 060●●● K	5.000
GBY 80	3:1, 4:1, 5:1 and 8:1	GBY 080●●● K	12.000
	12:1 and 20:1	GBY 080●●● K	14.000

(1) To order a GBY angular planetary gearbox, complete each of the above references as follows:

	GBY	●●●	●●●	K
Size	60 mm	060		
	80 mm	080		
Reduction ratio	3:1		003	
	4:1		004	
	5:1		005	
	8:1		008	
	12:1		012	
	20:1		020	
40:1		040		
Mounting with GBK adaptor kit (see page 43)				K

Integrated drive/GBY angular planetary gearbox combinations

Reduction ratios from 3:1 to 40:1

Type of integrated drive	Reduction ratio						
	3:1	4:1	5:1	8:1	12:1	20:1	40:1
ILA1●571T	GBY 60	GBY 60	GBY 60	GBY 60	GBY 60	GBY 60	GBY 60
ILA1●571P	GBY 60	GBY 60	GBY 60	GBY 60	GBY 60	GBY 60	GBY 60
ILA1●572T	GBY 60	GBY 60	GBY 60	GBY 60	GBY 60	GBY 60	GBY 60
ILA1●572P	GBY 60	GBY 60	GBY 60	GBY 60	GBY 60	GBY 60	GBY 60
ILA2●571T	GBY 60	GBY 60	GBY 60	GBY 60	GBY 60	GBY 60	GBY 60
ILA2●571P	GBY 60	GBY 60	GBY 60	GBY 60	GBY 60	GBY 60	GBY 60
ILA2●572T	GBY 60	GBY 60	GBY 60	GBY 60	GBY 60	GBY 60	GBY 60
ILA2●572P	GBY 60	GBY 60	GBY 60	GBY 60	GBY 60	GBY 60	GBY 60
ILE1●661P	–	–	–	–	GBY 60	GBY 60	GBY 60
ILE2●661P	–	–	–	–	GBY 60	GBY 60	GBY 60
ILE2●662P	–	–	–	–	GBY 60	GBY 60	GBY 60
ILS1●571P	GBY 60	GBY 60	GBY 60	GBY 60	GBY 60	GBY 60	GBY 60
ILS1●572P	GBY 60	GBY 60	GBY 60	GBY 60	GBY 60	GBY 60	GBY 60
ILS1●573P	GBY 60	GBY 60	GBY 60	GBY 60	GBY 60	GBY 60	GBY 60
ILS1●851P	GBY 80	GBY 80	GBY 80	GBY 80	GBY 80	GBY 80	–
ILS1●852P	GBY 80	GBY 80	GBY 80	GBY 80	GBY 80	GBY 80	–
ILS1●853P	GBY 80	GBY 80	GBY 80	GBY 80	GBY 80	GBY 80	–
ILS1●853T	GBY 80	GBY 80	GBY 80	GBY 80	GBY 80	GBY 80	–
ILS2●571P	GBY 60	GBY 60	GBY 60	GBY 60	GBY 60	GBY 60	GBY 60
ILS2●572P	GBY 60	GBY 60	GBY 60	GBY 60	GBY 60	GBY 60	GBY 60
ILS2●573P	GBY 60	GBY 60	GBY 60	GBY 60	GBY 60	GBY 60	GBY 60
ILS2●851P	GBY 80	GBY 80	GBY 80	GBY 80	GBY 80	GBY 80	–
ILS2●852P	GBY 80	GBY 80	GBY 80	GBY 80	GBY 80	GBY 80	–
ILS2●853P	GBY 80	GBY 80	GBY 80	GBY 80	GBY 80	GBY 80	–
ILS2●853T	GBY 80	GBY 80	GBY 80	GBY 80	GBY 80	GBY 80	–

GBY 060

For these combinations, you must check that the application will not exceed the maximum gearbox output torque (see the values on our website www.schneider-electric.com).

Motion control

Lexium integrated drives

Option: adaptor kit for GB● planetary gearboxes

References							
To order a GBK adaptor kit (1), complete each reference as follows:							
			GBK	●●●	●●●	●	F
Size of GBX or GBY planetary gearbox	Housing diameter	40 mm		040			
		60 mm		060			
		80 mm		080			
Associated integrated drive		ILA●●57, ILS●●57				057	
		ILE●●66				066	
		ILS●●85				085	
Compatibility		All types of motor				0	
		1 or 2 stage motors				2	
		3 stage motor				3	
Integrated drive adaptation		For ILA integrated drive					A
		For ILE integrated drive					E
		For ILS integrated drive					S

Integrated drive/GBK adaptor kit combination										
Type of gearbox	ILA●●571	ILA●●572	ILE1●661	ILE2●662	ILS●●571	ILS●●572	ILS●●573	ILS●●851	ILS●●852	ILS●●853
GBK 060 0570A	Compatible	Compatible	Not compatible	Not compatible	Not compatible	Not compatible	Not compatible	Not compatible	Not compatible	Not compatible
GBK 040 0660E	Not compatible	Not compatible	Compatible	Compatible	Not compatible	Not compatible	Not compatible	Not compatible	Not compatible	Not compatible
GBK 060 0660E	Not compatible	Not compatible	Compatible	Compatible	Not compatible	Not compatible	Not compatible	Not compatible	Not compatible	Not compatible
GBK 060 0572S	Not compatible	Not compatible	Not compatible	Not compatible	Compatible	Compatible	Not compatible	Not compatible	Not compatible	Not compatible
GBK 060 0573S	Not compatible	Not compatible	Not compatible	Not compatible	Not compatible	Not compatible	Compatible	Not compatible	Not compatible	Not compatible
GBK 080 0852S	Not compatible	Not compatible	Not compatible	Not compatible	Not compatible	Not compatible	Not compatible	Compatible	Compatible	Not compatible
GBK 080 0853S	Not compatible	Not compatible	Not compatible	Not compatible	Not compatible	Not compatible	Not compatible	Not compatible	Not compatible	Compatible

- Compatible
- Not compatible

- (1) Weight of adaptor kit:
- GBK 040 0660E: 0.244 kg
 - GBK 060 0570A: 0.210 kg
 - GBK 060 0572S: 0.223 kg
 - GBK 060 0573S: 0.218 kg
 - GBK 060 0660E: 0.255 kg
 - GBK 080 0852S: 0.423 kg
 - GBK 080 0853S: 0.416 kg

Motion control Lexium integrated drives

ILP●R for RS 485 serial link
With 2-phase stepper motor



ILP●R for RS 485 serial link
with integrated motion controller

Presentation

Lexium ILP●R integrated drives equipped with an RS 485 serial link interface comprise a 2-phase stepper motor and control electronics with integrated programmable motion controller.

They also have a multifunction interface which supports up to 11 signals for easy adaptation to different applications.

The control section comprises control electronics and a power stage which share a common power supply.

They are available in four flange sizes (36 mm, 42 mm, 57 mm and 85 mm).

Lexium ILP●R integrated drives can operate on the following power supplies:

- 24 V to 48 V DC for all motor types
- 230 V AC for 85 mm flange motors

Application example: material handling by automatic palletizer

Automatic palletizers meet the increasing need to transport products over long distances for storage management: a truck transports products to place them in position individually according to the palletization plan.

The Lexium ILP●R integrated drive is used to activate opening and closing of the pallet truck grabs and check that the product has not become jammed.

Interfaces

ILP●R integrated drives are equipped with the following interfaces:

- RS 485 serial link interface
- Multifunction interface

RS 485 serial link interface

The RS 485 serial link interface is used for commissioning, programming and maintaining ILP●R integrated drives using Lexium CT PC software (see page 5).

In order to simplify commissioning and maintenance, the software can use a direct link via an RS 485/USB converter.

Motion control

Lexium integrated drives

ILP●R for RS 485 serial link
With 2-phase stepper motor

Interfaces (continued)

Multifunction interface

The multifunction interface supports the following signals:

- 5 to 24 V signals, configurable as positive logic (Sink) or negative logic (Source) inputs or outputs
- An analog signal, configurable for voltage or current
- 0 to 5 V signal configurable as a capture input or trip output (version with industrial connector only)
- Two 0 to 5 V pulse/direction (P/D) signals, configurable as inputs or outputs (version with industrial connector only)

24 V I/O

The multifunction interface has 4 or 8 I/O, depending on the chosen type of connection:

- Version with flying leads or printed circuit board connectors:
Four 5 to 24 V signals (positive logic (Sink) or negative logic (Source) inputs or outputs)
- Version with industrial connectors: Eight 5 to 24 V signals, configurable as positive logic (Sink) or negative logic (Source) inputs or outputs

The signals can be used for the following predefined functions:

- Input functions:
Homing, + limit, - limit, go, stop, pause, JOG+, JOG-, universal function
- Output functions:
motion, error, stalling, change of speed, universal function

Analog input

The analog input is available on all models of ILP●R integrated drive.

It can be configured for voltage (0...5 V or 0...10 V $\overline{---$) or current (4 to 20 mA or 0 to 20 mA).

5 V capture input/trip output

This input/output is available on ILP●R integrated drives equipped with industrial connectors.

The high speed signal is used to capture the position of the axis or to control an external event when it is set as a trip output.

Pulse/direction (P/D) I/O

Pulse/direction (P/D) signals are available on ILP●R integrated drives equipped with industrial connectors.

They can control a third-party device.

The signals can be transmitted from a master controller, for example a Lexium Controller, or from another Lexium ILP●R integrated drive.

Special technical features

- High continuous maximum torque
- Good speed stability characteristics
- High resolution positioning
- Complete 1 or 2-character instruction set
- Configurable I/O
- Very compact

Motion control Lexium integrated drives

ILP●R for RS 485 serial link
With 2-phase stepper motor

Connection

Various types of connection are available, depending on the integrated drive model:

- Printed circuit board connectors for 36 mm flange
- Flying leads for 42, 57 and 85 mm flanges
- Industrial connectors for 42, 57 and 85 mm flanges

They are used to connect the power supply, multifunction interface or RS 485 serial link interface.

Printed circuit board connectors

Printed circuit board connectors are used to connect the power supply, the multifunction interface or the RS 485 serial link interface.



Flying leads

The flying leads are used to connect the power supply and the multifunction interface.

An additional printed circuit board connector is then used to connect the RS 485 serial link interface.



Industrial connectors

Various types of industrial connector are used, depending on the chosen power supply:

- For ILP2R integrated drives with 48 V $\overline{\text{DC}}$ power supply:
 - An M23 connector is used to connect the power supply and multifunction interface
 - An M12 connector is used to connect the RS 485 serial link interface
- For ILP5R integrated drives with 230 V \sim power supply:
 - An M23 connector is used to connect the multifunction interface
 - An M12 connector is used to connect the RS 485 serial link interface
 - A 3-pin connector is used to connect the power supply



Motion control

Lexium integrated drives

ILP●R for RS 485 serial link
With 2-phase stepper motor

Main functions

Lexium ILP●R integrated drives include the main functions required for motion control.

All function parameters are set via the RS 485 serial link interface using Lexium CT PC software.

The parameters can be saved to the Lexium ILP●R integrated drive's internal non-volatile memory.

Operating modes

Lexium ILP●R integrated drives can function in two operating modes:

- Manual mode (JOG)

In this mode, the commands and parameters are controlled directly with the Lexium CT PC software.

- Programmable mode

This mode is used to save programs in the motion controller incorporated in the Lexium ILP●R drive.

Motion functions

- Setting the number of steps (200 to 51,200)
- Speed profile
- Point-to-point mode
- Homing
- Electronic gearbox mode (for the version with industrial connectors)

Other functions

- Setting the transmission rate
- Configuring the I/O signals
- Setting the motor phase current (1 to 100% of nominal current)
- Mathematical functions (addition, subtraction, division, multiplication, AND, OR, XOR, NOT functions , etc.)
- Trip functions
- Encoder functions
- Program functions (calling a subroutine, creation of operation variables, etc.)
- ...

Note: For details of available functions, please visit our website www.schneider-electric.com.

Motion control Lexium integrated drives

ILP●R for RS 485 serial link
With 2-phase stepper motor

Description

ILP●R integrated drives equipped with an RS 485 serial link interface comprise a 2-phase stepper motor and control electronics with integrated programmable motion controller.

The integrated drive is programmed via the RS 485 serial link interface using Lexium CT PC software which can be used for point-to-point or multipoint configuration.

There are three types of connection, depending on the flange size:

- Flying leads
- Industrial connectors
- Printed circuit board connectors

Connection types

Flying leads



Connection via industrial connector



Connection via printed circuit board connector



Motion control Lexium integrated drives

ILP●R for RS 485 serial link
With 2-phase stepper motor



ILP●R integrated drive for RS 485 serial link

References												
Example:	I	L	P	2	R	3	6	1	M	N	1	A
Motor type P = 2-phase stepper motor	I	L	P	2	R	3	6	1	M	N	1	A
Supply voltage 2 = 24...48 V $\overline{\text{---}}$ 5 = 230 V \sim (for 85 mm flange only)	I	L	P	2	R	3	6	1	M	N	1	A
Communication interface R = RS 485	I	L	P	2	R	3	6	1	M	N	1	A
Flange size 36 = 36 mm 42 = 42 mm 57 = 57 mm 85 = 85 mm	I	L	P	2	R	3	6	1	M	N	1	A
Drive type (1) 1 = ILP●R●●1 2 = ILP●R●●2 3 = ILP●R●●3 4 = ILP●R●●4	I	L	P	2	R	3	6	1	M	N	1	A
Speed/torque index M = medium torque, medium rotation speed	I	L	P	2	R	3	6	1	M	N	1	A
Connection B = flying leads (except for motor with 36 mm flange ($\overline{\text{---}}$) and 85 mm flange (\sim)) C = industrial connector (except for motor with 36 mm flange ($\overline{\text{---}}$) and 85 mm flange ($\overline{\text{---}}$)) N = printed circuit board connector (for motor with 36 mm flange ($\overline{\text{---}}$))	I	L	P	2	R	3	6	1	M	N	1	A
Sensor type 1 = reference pulse sensor (Zero marker)	I	L	P	2	R	3	6	1	M	N	1	A
Holding brake A = without holding brake	I	L	P	2	R	3	6	1	M	N	1	A

(1) See the main characteristics and dimensions according to the type of drive in the table below:

Drive		ILP2R											ILP5R				
		361	421	422	423	571	572	573	574	851	852	853	851	852	853		
Nominal supply voltage	V $\overline{\text{---}}$	24...48											-				
	V \sim	-											230				
Holding torque	Nm	0.11	0.19	0.33	0.39	0.63	0.86	1.44	1.77	2.13	3.12	5.87	2.16	3.16	4.79		
Dimensions (overall in mm)	Flying leads	W x H	-			42.7 x 58.3			56.4 x 75.2			86.1 x 94.7			-		
		D	-			55.9	61.7	70.4	67.3	76.7	98.6	134.1	96.8	116.8	156.7	-	
	With industrial connector	W x H	-			42.9 x 70.9			56.4 x 75.2			-			87.8 x 164.2		
		D	-			77.7	83.6	92.2	88.4	97	118.6	-	-	155	174.3	214.3	
With printed circuit board connector	W x H	35.6 x 52			-												
	D	48.5			-												

Note: See all the data (characteristics, dimensions) on our website www.schneider-electric.com.

Motion control

Lexium integrated drives

ILT●A for CANopen machine bus

With 2-phase stepper motor



ILT●A for CANopen machine bus

Presentation

Lexium ILT●A integrated drives equipped with a CANopen machine bus interface comprise a 2-phase stepper motor and control electronics.

They also have a multifunction interface which supports up to 11 signals for easy adaptation to different applications.

The control section comprises control electronics and a power stage which share a common power supply.

They are available in four flange sizes (36 mm, 42 mm, 57 mm and 85 mm).

Lexium ILT●A integrated drives can operate on the following power supplies:

- 24 V to 48 V DC for all motor types
- 230 V AC for 85 mm flange motors

Application example: manufacture of solar panels

During their manufacture, solar panels are transported from one workstation to another via a conveyor belt.

In order to double production, two conveyors are used simultaneously to transport two lines of solar panels. The panels are stopped at each workstation, the position being determined using a camera placed inside the workstation.

The excellent positioning accuracy of Lexium ILT●A integrated drives makes them ideal for controlling the conveyor. Three Lexium ILT●A integrated drives are used for each conveyor line, with a total of six Lexium ILT●A drives operating simultaneously in each workstation.

Interfaces

ILT●A integrated drives are equipped with the following interfaces:

- CANopen machine bus interface
- Multifunction interface

CANopen machine bus interface

The CANopen machine bus interface is used for configuring and controlling the ILT●A integrated drive.

It is also used to connect the Lexium CT PC software (see page 5).

A CANopen/USB converter is then necessary (see accessories page 60).

Motion control

Lexium integrated drives

ILT●A for CANopen machine bus

With 2-phase stepper motor

Interfaces (continued)

Multifunction interface

The multifunction interface supports the following signals:

- 5 to 24 V signals, configurable as positive logic (Sink) or negative logic (Source) inputs or outputs
- An analog signal, configurable for voltage or current
- 0 to 5 V signal configurable as a capture input or trip output (version with industrial connector only)
- Two 0 to 5 V pulse/direction (P/D) signals, configurable as inputs or outputs (version with industrial connector only)

24 V I/O

The multifunction interface has 4 or 8 I/O, depending on the chosen type of connection:

- Version with flying leads or printed circuit board connectors:
Four 24 V signals (positive logic (Sink) or negative logic (Source) inputs or outputs)
- Version with industrial connectors: Eight 24 V signals, configurable as positive logic (Sink) or negative logic (Source) inputs or outputs

The signals can be used for the following predefined functions:

- Input functions:
Homing, + limit, - limit, go, stop, pause, JOG+, JOG-, universal function
- Output functions:
motion, error, stalling, change of speed, universal function

Analog input

The analog input is available on all models of ILT●A integrated drive.

It can be configured for voltage (0...5 V or 0...10 V $\overline{---$) or current (4 to 20 mA or 0 to 20 mA).

5 V capture input/trip output

This input/output is available on ILT●A integrated drives equipped with industrial connectors.

The high speed signal is used to capture the position of the axis or to control an external event when it is set as a trip output.

Pulse/direction (P/D) I/O

Pulse/direction (P/D) signals are available on ILT●A integrated drives equipped with industrial connectors.

They can control a third-party device.

The signals can be transmitted from a master controller, for example a Lexium Controller.

Special technical features

- High continuous maximum torque
- Good speed stability characteristics
- High resolution positioning
- Complete 1 or 2-character instruction set
- Configurable I/O
- Very compact

Motion control

Lexium integrated drives

ILT●A for CANopen machine bus

With 2-phase stepper motor

Connection

Various types of connection are available, depending on the integrated drive model:

- Printed circuit board connectors for 36 mm flange
- Flying leads for 42, 57 and 85 mm flanges
- Industrial connectors for 42, 57 and 85 mm flanges

They are used to connect the power supply, multifunction interface or RS 485 serial link interface.

Printed circuit board connectors

Printed circuit board connectors are used to connect the power supply and the multifunction interface.

An additional 9-way male SUB-D connector is then used to connect the CANopen machine bus interface.



Flying leads

The flying leads are used to connect the power supply and the multifunction interface.

An additional 9-way male SUB-D connector is then used to connect the CANopen machine bus interface.



Industrial connectors

Various types of industrial connector are used, depending on the chosen power supply:

- For ILT2A integrated drives with 48 V $\overline{\text{DC}}$ power supply:
 - An M23 connector is used to connect the power supply and multifunction interface
 - An M12 connector is used to connect the CANopen machine bus interface
- For ILT5A integrated drives with 230 V \sim power supply:
 - An M23 connector is used to connect the multifunction interface
 - An M12 connector is used to connect the CANopen machine bus interface
 - A 3-pin connector is used to connect the power supply



Motion control

Lexium integrated drives

ILT●A for CANopen machine bus
With 2-phase stepper motor

Main functions

Lexium ILT●A integrated drives include the main functions required for motion control, in particular:

Operating modes

The following operating modes can be set via the communication bus or using Lexium CT PC software:

- Speed profile
- Position profile
- Homing

Other operating modes can be activated via the communication bus or the Lexium CT PC software:

- Configuring the I/O
- Setting the motion profile via the profile generator
- Triggering the Quick Stop function
- Fast position capture via an input signal

Note: For details of available functions, please visit our website www.schneider-electric.com.

Motion control

Lexium integrated drives

ILT●A for CANopen machine bus

With 2-phase stepper motor

Description

ILT●A integrated drives equipped with a CANopen machine bus interface comprise a 2-phase stepper motor and control electronics.

They have a CANopen machine bus communication interface which supports the DS 301 and DSP 402 device profiles.

There are three types of connection, depending on the flange size:

- Flying leads
- Industrial connectors
- Printed circuit board connectors

Connection types

Flying leads



Connection via industrial connector



Connection via printed circuit board connector



Motion control

Lexium integrated drives

ILT●A for CANopen machine bus

With 2-phase stepper motor



ILT●A integrated drive for CANopen machine bus

References												
Example:	I	L	T	2	A	3	6	1	M	N	1	A
Motor type T = 2-phase stepper motor	I	L	T	2	A	3	6	1	M	N	1	A
Supply voltage 2 = 24...48 V $\overline{\text{---}}$ 5 = 230 V \sim (for 85 mm flange only)	I	L	T	2	A	3	6	1	M	N	1	A
Communication interface A = CANopen DS 301 or DSP 402	I	L	T	2	A	3	6	1	M	N	1	A
Flange size 36 = 36 mm 42 = 42 mm 57 = 57 mm 85 = 85 mm	I	L	T	2	A	3	6	1	M	N	1	A
Drive type (1) 1 = ILT●A●●1 2 = ILT●A●●2 3 = ILT●A●●3 4 = ILT●A●●4	I	L	T	2	A	3	6	1	M	N	1	A
Speed/torque index M = medium torque, medium rotation speed	I	L	T	2	A	3	6	1	M	N	1	A
Connection B = flying leads (except for motor with 36 mm flange ($\overline{\text{---}}$) and 85 mm flange (\sim)) C = industrial connector (except for motor with 36 mm flange ($\overline{\text{---}}$) and 85 mm flange ($\overline{\text{---}}$)) N = printed circuit board connector (for motor with 36 mm flange ($\overline{\text{---}}$))	I	L	T	2	A	3	6	1	M	N	1	A
Sensor type 1 = reference pulse sensor (Zero marker)	I	L	T	2	A	3	6	1	M	N	1	A
Holding brake A = without holding brake	I	L	T	2	A	3	6	1	M	N	1	A

(1) See the main characteristics and dimensions according to the type of drive in the table below:

Drive	ILT2A											ILT5A					
	361	421	422	423	571	572	573	574	851	852	853	851	852	853			
Nominal supply voltage	V $\overline{\text{---}}$	24...48											-				
	V \sim	-											230				
Holding torque	Nm	0.11	0.19	0.33	0.39	0.63	0.86	1.44	1.77	2.13	3.12	5.87	2.16	3.16	4.79		
Dimensions (overall in mm)	Flying leads	W x H	-			42.7 x 58.3			56.4 x 75.2			86.1 x 105.5			-		
		D	-			55.9	61.7	70.4	67.3	76.7	98.6	134.1	96.8	116.8	156.7	-	
	With industrial connector	W x H	-			42.9 x 70.9			56.4 x 75.2			-			87.8 x 164.2		
		D	-			77.7	83.6	92.2	88.4	97	118.6	-	-	155	174.3	214.3	-
	With printed circuit board connector	W x H	35.6 x 52.3			-											
		D	49			-											

Note: See all the data (characteristics, dimensions) on our website www.schneider-electric.com.

Motion control

Lexium integrated drives

ILT●V with pulse/direction (P/D) interface

With 2-phase stepper motor



ILT●V with pulse/direction (P/D) interface

Presentation

Lexium ILT●V integrated drives equipped with a pulse/direction (P/D) interface comprise a 2-phase stepper motor, control electronics and a multifunction interface.

The control section comprises control electronics and a power stage which share a common power supply.

They are available in four flange sizes (36 mm, 42 mm, 57 mm and 85 mm).

Lexium ILT●V integrated drives can operate on the following power supplies:

- 24 V to 48 V DC for all motor types
- 230 V AC for 85 mm flange motors

Application example

When an installation requires monitoring of a person's or a product's level of exposure to ionizing radiation, disposable badges are used to ensure that there has not been any excessive exposure.

A measuring instrument, the dosimeter, reads the radiation level of each badge. The reading process is carried out in two steps: the badge must first of all have been activated, then it is transported to a second workstation where a sensor detects the radiation dose of the badge.

The Lexium ILT●V integrated drive controls the transport of the badges from one workstation to another via a worm gear.

Interfaces

ILT●V integrated drives are equipped with the following interfaces:

- SPI serial link interface
- Multifunction interface

SPI serial link interface

The SPI serial link interface is used to connect the integrated drive to the Lexium CT PC software during configuration, commissioning or maintenance.

It can be used, for example, to configure the following functions:

- Setting the motor phase current
- Setting the number of steps
- Configuring the pulse train
- Configuring the input signal filter
- ...

In order to simplify commissioning and maintenance, the software can be used via an SPI/USB converter.

Multifunction interface

The multifunction interface supports the following signals:

- 5 to 24 V signals separated by optical coupler:
- The reference values are transmitted via two pulse/direction (P/D) signals
- The other signals have the following functions:
 - Activation/locking of the power stage and activation/locking of the indexing pulse
 - Configuration of the input as positive (Sink) or negative (Source) logic

Special technical features

- High continuous maximum torque
- Good speed stability characteristics
- High resolution positioning
- Very compact

Motion control

Lexium integrated drives

ILT●V with pulse/direction (P/D) interface
With 2-phase stepper motor



Integrated drive with printed circuit board connector



Integrated drive with flying leads



Integrated drives with industrial connector

Connection

Various types of connection are available, depending on the integrated drive model:

- Printed circuit board connectors for 36 mm flange
- Flying leads for 42, 57 and 85 mm flanges
- Industrial connectors for 42, 57 and 85 mm flanges

They are used to connect the power supply, multifunction interface or commissioning interface.

Printed circuit board connectors

Printed circuit board connectors are used to connect the power supply, the multifunction interface and the SPI serial link.

Flying leads

The flying leads are used to connect the power supply and the multifunction interface.

An additional printed circuit board connector is then used to connect the SPI serial link interface.

Industrial connectors

Various types of industrial connector are used, depending on the chosen power supply:

- For ILT2V integrated drives with 48 V $\overline{\text{DC}}$ power supply:
 - An M23 connector is used to connect the power supply, multifunction interface and SPI serial link
- For ILT5V integrated drives with 230 V \sim power supply:
 - An M23 connector is used to connect the multifunction interface and SPI serial link
 - A 3-pin connector is used to connect the power supply

Main functions

Configuration by parameter switch

The following functions can be set on ILT●V integrated drives via the parameter switch:

- Setting the number of steps
- Setting the motor phase current
- Reducing the motor phase current
- Input signal functions:
 - Transmission of the reference value via pulse/direction (PULSE/DIR) or encoder (A/B) signals
 - Activation/locking of the power stage (ENABLE/GATE input signal)
 - Activation/locking of the indexing pulse (ENABLE/GATE input signal)
- Adjusting the input filter

Note: For details of available functions, please visit our website www.schneider-electric.com.

Motion control

Lexium integrated drives

ILT●V with pulse/direction (P/D) interface
With 2-phase stepper motor

Description

ILT●V integrated drives equipped with a pulse/direction (P/D) interface comprise a 2-phase stepper motor and control electronics.

The configuration of ILT●V integrated drives can be modified on the fly or downloaded and saved to a non-volatile memory using the Lexium CT PC software tool. The parameters can be modified via the SPI serial link interface.

There are three types of connection, depending on the flange size:

- Flying leads
- Industrial connectors
- Printed circuit board connectors

Connection types

Flying leads



Connection via industrial connector



Connection via printed circuit board connector



Motion control

Lexium integrated drives

ILT●V with pulse/direction (P/D) interface
With 2-phase stepper motor



ILT●V integrated drive with pulse/direction (P/D) interface

References												
Example:	I	L	T	2	V	3	6	1	M	N	0	A
Motor type T = 2-phase stepper motor	I	L	T	2	V	3	6	1	M	N	0	A
Supply voltage 2 = 24...48 V $\overline{\text{---}}$ 5 = 230 V \sim (for 85 mm flange only)	I	L	T	2	V	3	6	1	M	N	0	A
Communication interface V = pulse/direction (P/D)	I	L	T	2	V	3	6	1	M	N	0	A
Flange size 36 = 36 mm 42 = 42 mm 57 = 57 mm 85 = 85 mm	I	L	T	2	V	3	6	1	M	N	0	A
Drive type (1) 1 = ILT●V●●1 2 = ILT●V●●2 3 = ILT●V●●3 4 = ILT●V●●4	I	L	T	2	V	3	6	1	M	N	0	A
Speed/torque index M = medium torque, medium rotation speed	I	L	T	1T	V	3	6	1	M	N	0	A
Connection B = flying leads (except for motor with 36mm flange ($\overline{\text{---}}$) and 85 mm flange (\sim)) C = industrial connector (except for motor with 36 mm flange ($\overline{\text{---}}$) and 85 mm flange ($\overline{\text{---}}$)) N = printed circuit board connector (for motor with 36 mm flange ($\overline{\text{---}}$))	I	L	T	2	V	3	6	1	M	N	0	A
Sensor type 0 = without sensor	I	L	T	2	V	3	6	1	M	N	0	A
Holding brake A = without holding brake	I	L	T	2	V	3	6	1	M	N	0	A

(1) See the main characteristics and dimensions according to the type of drive in the table below:

Drive	ILT2V											ILT5V						
	361	421	422	423	571	572	573	574	851	852	853	851	852	853				
Nominal supply voltage	V $\overline{\text{---}}$	24...48											-					
	V \sim	-											230					
Holding torque	Nm	0.11	0.19	0.33	0.39	0.63	0.86	1.44	1.77	2.13	3.12	5.87	2.16	3.16	4.79			
Dimensions (overall in mm)	Flying leads	W x H	-			42.7 x 58.3				56.4 x 75.2			86.1 x 94.7			-		
		D	-			55.9	61.7	70.4	67.3	76.7	98.6	134.1	96.8	116.8	156.7	-		
	With industrial connector	W x H	-			42.9 x 70.9				56.4 x 75.2			-			87.8 x 164.2		
		D	-			77.7	83.6	92.2	88.4	97	118.6	-	-	-	155	174.3	214.3	
	With printed circuit board connector	W x H	35.6 x 52			-												
		D	48.5			-												

Note: See all the data (characteristics, dimensions) on our website www.schneider-electric.com.

Motion control

Lexium integrated drives

Accessories for IL● integrated drives

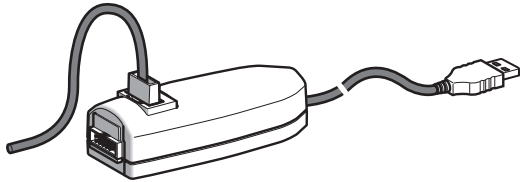

RS 485/USB converter for ILP●R integrated drive

Accessories for ILP●R integrated drives

Description	Length m	Reference	Weight kg
-------------	-------------	-----------	--------------

RS 485/USB converters for ILP●R integrated drive with RS 485 serial link interface

Preassembled converters with:

■ One USB connector			
■ One RS 485 connector for integrated drive:			
□ with industrial connector	3.6	VW3L1R401	0.191
□ with flying leads	3.6	VW3L1R402	0.209
□ with printed circuit board connector	3	VW3L1R403	0.417

Cordsets for ILP2R integrated drive

Cordset for integrated drive with flying leads

Preassembled cordset with:	3	VW3L3D02R30	0.181
■ Integrated drive end: one connector for RS 485 serial link			
■ Other end: flying leads			

Cordset for integrated drive with industrial connector

Preassembled cordset with:	4	VW3L3D01R40	1.089
■ Integrated drive end: one M23 (19-way) industrial connector for power supply and multifunction interface			
■ Other end: flying leads			

Cordset for integrated drive with printed circuit board connector

Preassembled cordset with:	3	VW3L3D04R30	0.272
■ Integrated drive end: one printed circuit board connector for power supply, multifunction interface and RS 485 serial link			
■ Other end: flying leads			

Cordsets for ILP5R integrated drive

Cordsets for integrated drive with industrial connector

Preassembled cordsets with:			
■ At one end: flying leads			
■ Integrated drive end:			
□ One 3-pin industrial connector for power supply	4	VW3L3P01R40	0.372
□ One M23 (19-way) industrial connector for multifunction interface	4	VW3L3D01R40	1.089

Accessories for ILT●A integrated drives

Description	Length m	Reference	Weight kg
-------------	-------------	-----------	--------------

CANopen/USB converter for ILT●A integrated drive with CANopen interface

Preassembled converter with:	3.6	VW3L1A500	0.136
■ One USB connector			
■ One 9-way male SUB-D connector (converter connection cable not included)			

Cordset for ILT2A integrated drive

Cordset for integrated drive with printed circuit board connector

Preassembled cordset with:	3	VW3L3P02R30	0.399
■ Integrated drive end: one printed circuit board connector for power supply and multifunction interface			
■ Other end: flying leads			

Cordset for ILT5A integrated drive

Cordset for integrated drive with industrial connector

Preassembled cordset with:			
■ At one end: flying leads			
■ Integrated drive end:			
□ One 3-pin industrial connector for power supply	4	VW3L3P01R40	0.372
□ One M23 (19-way) industrial connector for multifunction interface	4	VW3L3D01R40	1.089

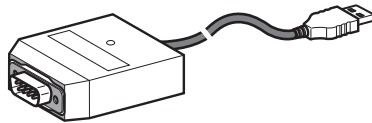

CANopen/USB converter for ILT●A integrated drive

Motion control integrated drives

Accessories for ILT●V integrated drives

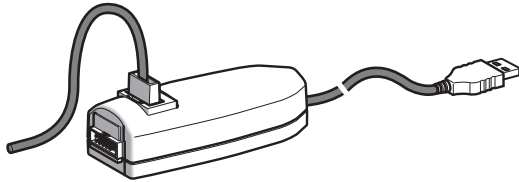

SPI/USB converter for ILT●V integrated drive

Accessories for ILT●V integrated drives

Description	Length m	Reference	Weight kg
SPI/USB converters for ILT●V integrated drive with pulse/direction (P/D) interface			
Preassembled converters with:			
■ One USB connector			
■ One SPI connector for integrated drive:			
□ with flying leads	3.6	VW3L1V300	0.127
□ with industrial connector	3.6	VW3L1V301	0.179
□ with printed circuit board connector	3.6	VW3L1V305	0.399

Cordsets for ILT2V integrated drive

Cordset for integrated drive with industrial connector

Preassembled cordset with:	4	VW3L3D01R40	1.089
■ Integrated drive end: one M23 (19-way) industrial connector for power supply, multifunction interface and SPI serial link			
■ Other end: flying leads			

Cordset for integrated drive with printed circuit board connector

Preassembled cordset with:	3	VW3L3D04R30	0.272
■ Integrated drive end: one printed circuit board connector for power supply, multifunction interface and SPI serial link			
■ Other end: flying leads			

Cordset for ILT5V integrated drive

Cordset for integrated drive with industrial connector

Preassembled cordset with:			
■ At one end: flying leads			
■ Integrated drive end:			
□ One 3-pin industrial connector for power supply	4	VW3L3P01R40	0.372
□ One M23 (19-way) industrial connector for multifunction interface	4	VW3L3D01R40	1.089

Schneider Electric Industries SAS

www.schneider-electric.com

Head Office
35, rue Joseph Monier
F-92500 Rueil-Malmaison
France

The information provided in this documentation contains general descriptions and/or technical characteristics of the performance of the products contained herein. This documentation is not intended as a substitute for and is not to be used for determining suitability or reliability of these products for specific user applications. It is the duty of any such user or integrator to perform the appropriate and complete risk analysis, evaluation and testing of the products with respect to the relevant specific application or use thereof. Neither Schneider Electric nor any of its affiliates or subsidiaries shall be responsible or liable for misuse of the information contained herein.

Design: Schneider Electric
Photos: Schneider Electric
Printed by: